



C. PCT 1002
-76

September 17, 2004

Madam,
Sir,

This circular is addressed to your Office in its capacity as receiving Office and/or designated or elected Office under the Patent Cooperation Treaty (PCT). It is also addressed to certain non-governmental organizations as well as PCT data subscribers. The Circular proposes a more efficient manner in presenting translations of text matter in drawings for the purposes of publication in the electronic version of the *PCT Gazette*.

Background and present situation

It is recalled that, according to PCT Rule 86.2(c), the electronic version of the *PCT Gazette* is made accessible both in English and French and contains, pursuant to PCT Rule 86.1(b)(ii), among other data and where available, a drawing or drawings (if any) appearing on the front page of the PCT pamphlet. Depending on the language of publication of the international application, a translation into English and/or French of certain data, namely the title of the invention, the abstract, and any text matter in the characteristic drawing, has to be prepared by the International Bureau.

The current practice of the International Bureau in respect of text matter in drawings published in the electronic version of the *PCT Gazette* is to completely remove the original language text and to replace it with the translated text within the drawing itself. This procedure of removing the original text from the drawings and replacing it has proved to be a time consuming and labor-intensive process.

/...

Proposed new approach

It is therefore proposed that in the electronic version of the *PCT Gazette*, the original language text matter will be left in the drawing and, in case the applicant did not indicate a reference sign, that a reference by way of an identifying letter or numeric code would be added to each text entry. Those codes would then be repeated in a legend next to the drawing where a translation of the respective text matter would be provided (for an illustration of this proposal, see Annex I which contains a sample of a drawing as filed, Annex II for the current approach in relation to that sample drawing and Annex III for the proposed new format). Note that this proposed new approach for the electronic version of the *PCT Gazette* is what is currently done for drawings which appear on the front page on the PCT pamphlets and in relation to which the text matter in the drawings is not in English.

The proposed new procedure would eliminate the need for removing the original text matter in the drawings and would thereby represent a considerable productivity gain for the International Bureau in the process of publication of the electronic version of the *PCT Gazette*. It is proposed to adopt this new procedure regardless of the amount of text contained in a drawing.

Observations and/or comments

The International Bureau would appreciate receiving your observations and/or comments on the proposed change in the way in which translated text matter in the representative drawing is displayed in the electronic version of the *PCT Gazette*, if any, by October 15, 2004. It is currently the intention of the International Bureau that the proposed practice change be implemented in the electronic version of the PCT Gazette as from December 1, 2004.

Sincerely yours,



Francis Gurry
Deputy Director General

Enclosures: Annex I – Sample of drawing as filed
Annex II – Current practice
Annex III – Proposed new practice

Annex I to Circular C. PCT 1002

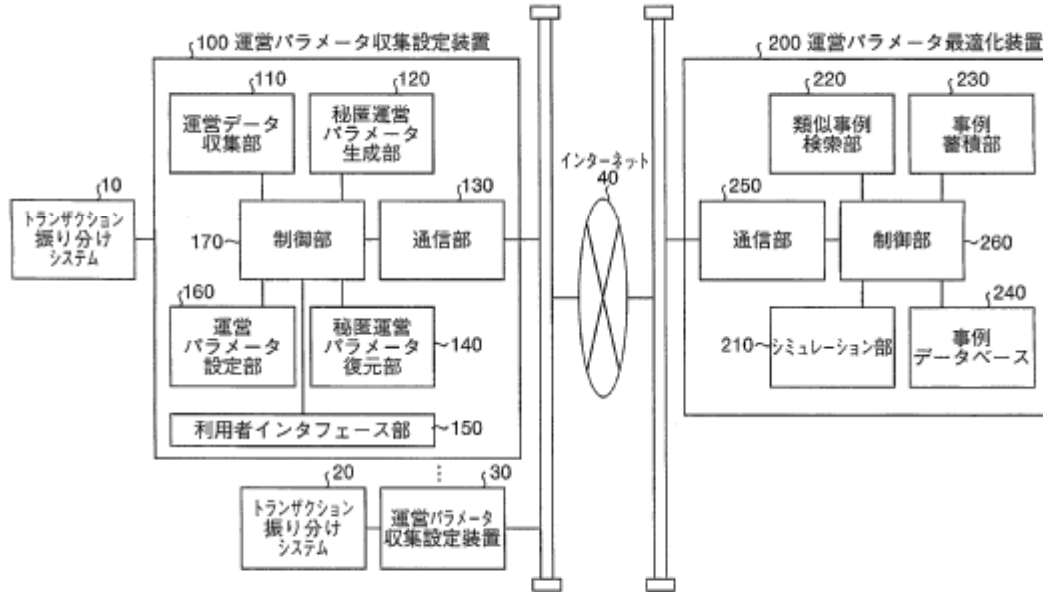

Annex II to Circular C. PCT 1002

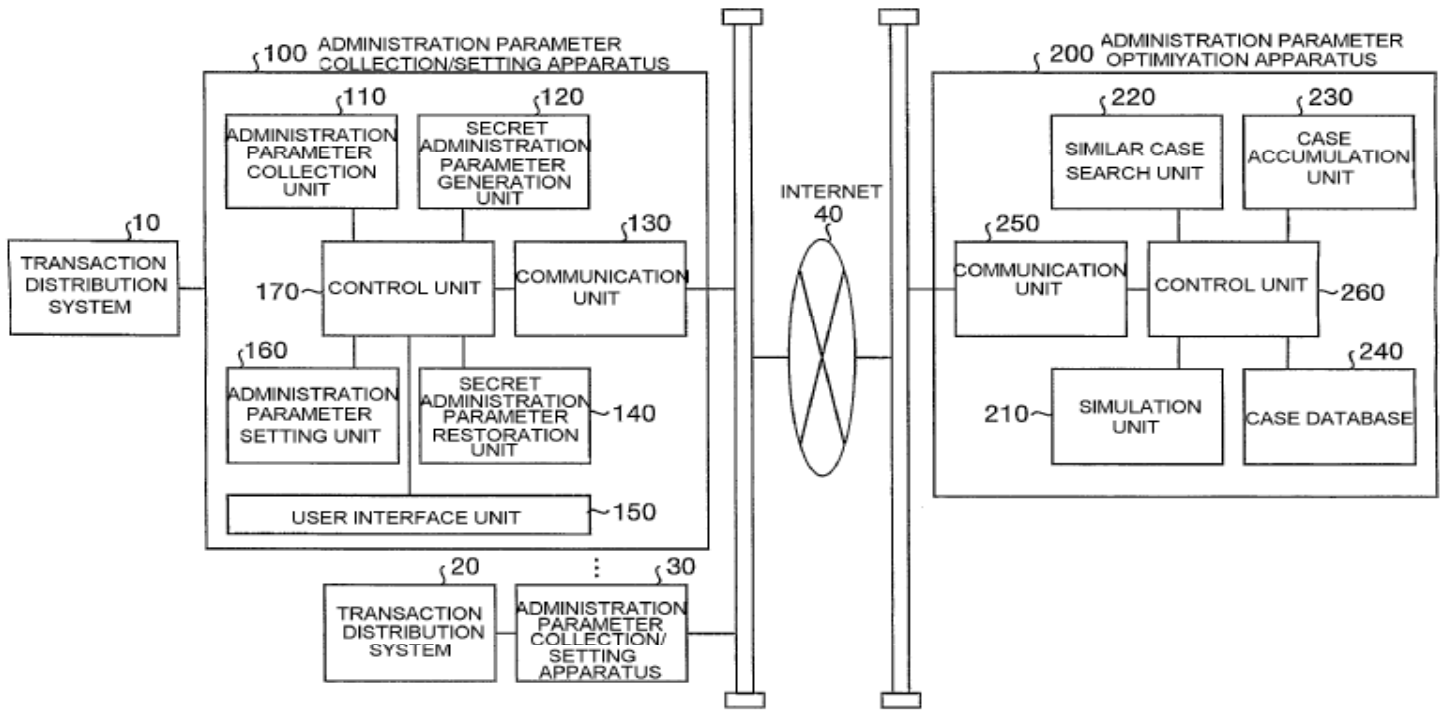

Annex III to Circular C. PCT 1002

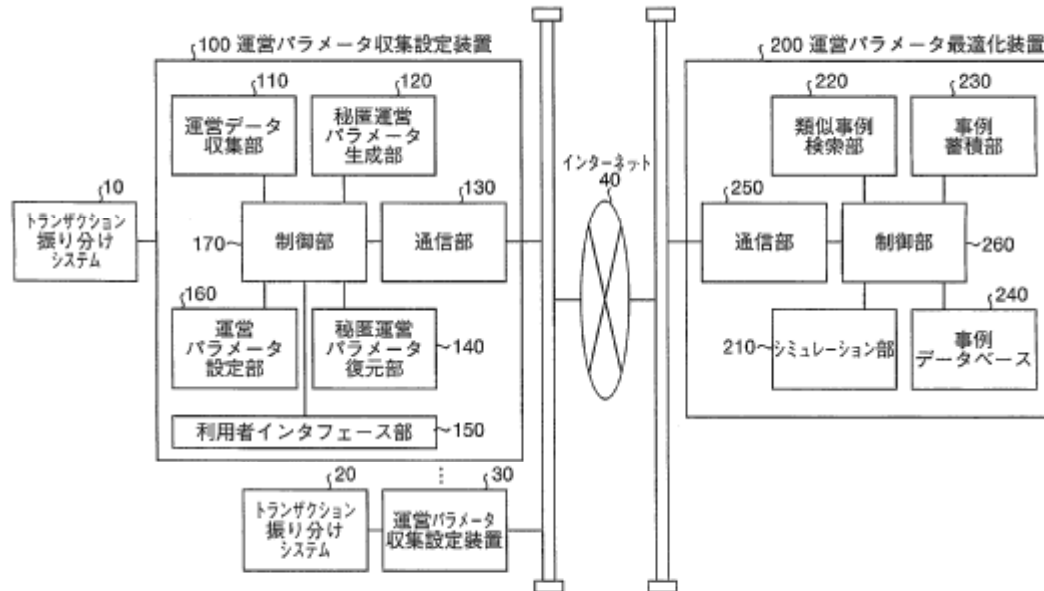

- | | | | |
|-----|---|-----|---|
| 100 | ADMINISTRATION PARAMETER COLLECTION/SETTING APPARATUS | 150 | USER INTERFACE UNIT |
| 110 | ADMINISTRATION PARAMETER COLLECTION UNIT | 20 | TRANSACTION DISTRIBUTION SYSTEM |
| 120 | SECRET ADMINISTRATION PARAMETER GENERATION UNIT | 30 | ADMINISTRATION PARAMETER COLLECTION/SETTING APPARATUS |
| 130 | COMMUNICATION UNIT | 200 | ADMINISTRATION PARAMETER OPTIMIZATION APPARATUS |
| 140 | SECRET ADMINISTRATION PARAMETER RESTORATION UNIT | 220 | SIMILAR CASE SEARCH UNIT |
| 150 | USER INTERFACE UNIT | 230 | CASE ACCUMULATION UNIT |
| 160 | ADMINISTRATION PARAMETER SETTING UNIT | 250 | COMMUNICATION UNIT |
| 170 | CONTROL UNIT | 260 | CONTROL UNIT |
| 180 | | 210 | SIMULATION UNIT |
| 190 | | 240 | CASE DATABASE |
| 200 | ADMINISTRATION PARAMETER OPTIMIZATION APPARATUS | 40 | INTERNET |