

Working Group on the Legal Development of the Hague System for the International Registration of Industrial Designs

Fifth Session
Geneva, December 14 to 16, 2015

PROPOSAL FOR RECOMMENDATIONS RELATING TO THE DISCLOSURE OF AN INDUSTRIAL DESIGN IN AN INTERNATIONAL APPLICATION

Document prepared by the International Bureau

I. INTRODUCTION

BACKGROUND

1. As the Hague System for the International Registration of Industrial Designs (hereinafter referred to as the “Hague System”) expands and as more jurisdictions with a so-called “Examining Office”¹ become members of the Hague System, Rule 9(4) of the Common Regulations Under the 1999 Act and the 1960 Act of the Hague Agreement (hereinafter referred to as the “Common Regulations”) will become increasingly relevant. Given that the Examining Offices define the contents and scope of the claimed industrial design based on its reproductions and/or description, it is foreseeable that, according to the said Rule, those Offices would exercise the right to refuse the effects of the international registration if they consider that the design has not been sufficiently disclosed.

¹ Pursuant to Article 1(xvii) of the 1999 Act, an “Examining Office” is defined as an “Office which *ex officio* examines applications filed with it for the protection of industrial designs at least to determine whether the industrial designs satisfy the condition of novelty”. Based on the declarations under the Hague System, which may only be made by Contracting Parties with an Examining Office, and information regarding examination procedures at Offices obtained by the International Bureau, the Offices of Hungary, Japan, Kyrgyzstan, the Republic of Korea, the Republic of Moldova, Romania, the Syrian Arab Republic and the United States of America are deemed to be Examining Offices under the Hague System.

2. Since the criteria for sufficient disclosure of an industrial design may be different from one jurisdiction to another, an applicant might not know how to disclose an industrial design according to the requirements of different Offices. Therefore, the applicant may face a situation where the reproductions contained in the international application satisfy the requirements of the Office of one of the designated Contracting Parties but are not deemed to be sufficient to disclose fully the industrial design before the Office of another designated Contracting Party.

3. In order to avoid refusals on the ground of insufficient disclosure of an industrial design, the applicant must be aware of the appropriate ways to meet the requirements for sufficient disclosure of an industrial design before the Examining Offices². In this respect, several user organizations and individuals have approached the International Bureau for guidance regarding appropriate ways of disclosing a design.

PURPOSE OF THE DOCUMENT

4. It is recalled that the amendments to Part Four of the Administrative Instructions for the Application of the Hague Agreement (hereinafter referred to as the “Administrative Instructions”), which came into force on July 1, 2014, intended to mitigate the risk of refusals pursuant to Rule 9(4) of the Common Regulations. The amendments to Sections 402, 403 and 405 of the Administrative Instructions relaxed certain formal requirements regarding the reproductions and representations of the industrial design contained in the international application and afforded applicants more flexibility in terms of providing elements that may be useful with regard to improved disclosure of the industrial design.

5. While the legal framework of the Hague System has been so updated, the International Bureau wishes to further assist the users of the system by offering guidance on “best practices”. However, this guidance may not be finalized without the input and endorsement of the members of the Hague Union³.

6. The purpose of the present document is to invite the fifth session of the Working Group to discuss the draft “Guidance for Users of the Hague System Concerning Effective Measures to Avoid Possible Refusals by the Examining Offices on the Ground that an Industrial Design that is the subject of an International Registration has not been Sufficiently Disclosed” (hereinafter referred to as the “Guidance”). The draft Guidance, which is contained in the Annex to the present document, has been prepared by the International Bureau based on its analysis of the legal texts of a number of Contracting Parties and the information provided through informal consultations regarding examination practices at some Offices. The draft Guidance makes a number of recommendations to forestall a possible refusal by an Examining Office. If endorsed by the Working Group, the recommendations will be made available to the users of the Hague System on the WIPO website.

² The number of notifications of refusal in 2013 and 2014 were, respectively, 123 and 122. In the first half of 2015, the number of the notifications of refusal amounted to 105, of which 55 were issued by the Korean Intellectual Property Office (KIPO). Among those refusals issued by KIPO, 65 per cent (70 per cent on the basis of the number of the designs contained in the international registrations designating the Republic of Korea) were based on the ground of insufficient disclosure of the design.

³ See paragraph 4 of document H/LD/WG/4/5, entitled “Proposal for Amendments to Part Four of the Administrative Instructions” which is available on the WIPO website at: http://www.wipo.int/meetings/en/details.jsp?meeting_id=32042.

II. LEGAL FRAMEWORK OF THE HAGUE SYSTEM

FORMAL EXAMINATION PERFORMED BY THE INTERNATIONAL BUREAU

7. Pursuant to Article 10(1) of the Geneva (1999) Act of the Hague Agreement Concerning the International Registration of Industrial Designs (hereinafter referred to as the “1999 Act”) and Rule 15(1) of the Common Regulations, an industrial design is registered by the International Bureau, if the international application complies with the formal requirements under the Hague System. As laid out in Rule 9(1) of the Common Regulations and Part Four of the Administrative Instructions, the formal requirements concern the reproductions and representation of an industrial design, such as, the quality of reproductions, contents and dimension of the representation of an industrial design or methods for disclaimer of protection.

8. It should be recalled that, as prescribed in Article 12(1) of the 1999 Act, no Office may refuse the effects of the international registration on the ground that requirements relating to the form or contents of the international application, which are the same as, additional to, or different from the requirements of the legal framework of the Hague System, have not been satisfied. In other words, the International Bureau exclusively exercises the examination as to formal requirements regarding the international registration.

9. This principle is binding upon all of the Contracting Parties. However, there is one exception, namely that if a Contracting Party has made a declaration under Rule 9(3) of the Common Regulations⁴ to the effect that certain specific views of the product or products which constitute the industrial design, or in relation to which the industrial design is to be used, are required, the Office of the said Contracting Party may refuse the effects of the international registration on the ground that certain views, as specified in the declaration, have not been submitted.

SUBSTANTIVE EXAMINATION BY THE OFFICE OF A DESIGNATED CONTRACTING PARTY

Possible refusal on the ground of insufficient disclosure of an industrial design under Rule 9(4) of the Common Regulations

10. The conditions for the grant of protection, such as the definition of a design⁵, novelty of a design, etc., are provided for in the national/regional legislations. According to Article 12 of the 1999 Act, the Office of a Contracting Party may refuse the effects of an international registration where substantive conditions under the law of that Contracting Party are not met in respect of an industrial design that is the subject of the international registration. As explained above, Rule 9(4) of the Common Regulations further specifies that, in particular, the Office of a Contracting Party may refuse the effects of the international registration on the substantive ground that the reproductions contained in the international registration are not sufficient to disclose fully the industrial design.

⁴ A declaration under Rule 9(3) of the Common Regulations has been made by two Contracting Parties, namely, Japan and the Republic of Korea.

⁵ Products belonging to Class 32 of the Locarno Classification cannot receive protection under the Industrial Design Protection Law of the Republic of Korea. Consequently, any designation of the Republic of Korea in an international registration for industrial designs in Class 32 would be the subject of a refusal by KIPO.

11. It should be noted that even if the reproductions comply with the requirements concerning views, as specified in a declaration made under Rule 9(3) by a Contracting Party, the Office of that Contracting Party may still issue a refusal on the ground of insufficient disclosure of an industrial design pursuant to Rule 9(4). For example, where the reproductions show six views of the product, as specified in the declaration under Rule 9(3) made by Japan⁶, the Japan Patent Office (JPO) nevertheless may refuse the effects of the international registration on the ground that the said reproductions are not sufficient to disclose fully the industrial design. This may be the case, for example, where the concavity and convexity of the surface of the product have been ambiguously shown in those six reproductions.

12. In terms of the implementation of Rule 9(4) of the Common Regulations, Note R9.09 of the “Basic Proposal for the Regulations under the New Act of the Hague Agreement Concerning the International Registration of Industrial Designs” (hereinafter referred to as the “Basic Proposal”)⁷, serves as an important reference and reads as follows: “A Contracting Party may however refuse on the ground that a reproduction does not sufficiently disclose the appearance of the industrial design. Thus, for example, although it may not refuse protection on the sole ground that a reproduction is not provided with surface shading, it may refuse if the only way to sufficiently disclose the industrial design is to provide surface shading, and that this has not been done. In such a case, the reason for refusal would be the substantive ground that the industrial design is not sufficiently disclosed, *not* the formal ground that the reproduction does not contain surface shading.”

III. DIFFERENT CRITERIA FOR DISCLOSURE OF AN INDUSTRIAL DESIGN

CONCEPT OF AN EXAMINING OFFICE AND NON-EXAMINING OFFICE

13. Under the Hague System, the Offices of the Contracting Parties may be divided into two groups, namely: “Examining Offices” that *ex officio* examine applications at least to determine whether the industrial designs satisfy the condition of novelty according to the applicable law⁸, and “non-Examining Offices”. To be precise, some of the non-Examining Offices may *ex officio* carry out limited substantive examinations, for instance, as to local novelty of the design. Further, some non-Examining Offices may conduct a substantive examination following an opposition by a third party.

14. In general, it is of the utmost importance to the Examining Offices to be able to understand, without any conjecture, clearly and completely the contents of the design for which protection is sought from the reproductions and other information in the application. This is because constitution of an entire disclosure of an industrial design is needed in order to determine whether the design meets the substantive conditions, especially the one as to novelty in comparison with another prior design.

⁶ The declaration under Rule 9(3) of Japan reads: “Where the product which constitutes the industrial design is three-dimensional, a front view, a back view, a top view, a bottom view, a left side view and a right side view, each made in compliance with the method of orthographic projection, are required”.

⁷ Refer to page 276 of the English version of the Records of the Diplomatic Conference for the Adoption of a New Act of the Hague Agreement Concerning the International Deposit of Industrial Designs (Geneva Act).

⁸ In this context, it is observed that KIPO is considered as an Examining Office only in terms of its examination as to international registrations containing products in the classes other than the Classes 2, 5 or 19 of the Locarno Classification. Regarding Classes 2, 5 or 19, KIPO does not carry out a full substantive examination under its national law.

CONVERGENCE PROGRAM INITIATED BY THE OFFICE FOR HARMONIZATION IN THE INTERNAL MARKET (TRADE MARKS AND DESIGNS) (OHIM)

15. The Convergence Programme was established in 2011 by the Office for Harmonization in the Internal Market (Trade Marks and Designs) (OHIM) of the European Union. To build on this momentum, OHIM and WIPO have established a close partnership within the framework of this Programme. Among others, WIPO has participated in the Convergence Programme – CP6: Project Graphic Representation of a Design, launched by OHIM⁹.

16. OHIM is considered as a non-Examining Office under the Hague System. In 2014, the European Union was the most designated Contracting Party, accounting for 17.5 per cent of all designs in designations. The work by the CP6 Working Group will be the reference for European Union national and regional IP Offices, user associations, applicants and representatives on the common practice of the requirements for graphic representation of designs within the European Union.

PROTECTION OF AN INDUSTRIAL DESIGN IN DIFFERENT JURISDICTIONS

17. It is important for the applicant to disclose the design sufficiently in the initial application with due regard for appropriate common measures to meet the requirements among the designated Contracting Parties. Attention should be paid to the fact that once the effects of the international registration are refused by the Office on the ground of failure to disclose the design sufficiently, the refusal cannot be overcome by requesting an amendment of the original representation by disclosing the parts which were considered ambiguous by the Office's examiner. That is to say, if the amendment were intended to add new matter to the original representation or to bring a change beyond the scope of identity of the design as originally disclosed, the amendment would not be accepted and the refusal would not be withdrawn by the Office.

18. However, it is also important to note that by taking such measures, the disclosure of the design to the same extent and a complete disclosure of an industrial design would rather narrow the scope of the protection in the Contracting Parties not requiring those elements.

IV. PROPOSAL FOR GUIDANCE

19. It is proposed that the International Bureau provide users of the Hague System with guidance, as provided in the draft Guidance contained in the Annex hereto, concerning effective measures to avoid possible refusals which may be raised by an Examining Office on the ground of insufficient disclosure of an industrial design in the international registration.

⁹ Participants of the Convergence Project 6 (CP6): Convergence on graphic representations of design are Office for Harmonization in the Internal Market (Trade Marks and Designs) (OHIM), national Offices of the European Union member states, Benelux Office for Intellectual Property (BOIP), Icelandic Patent Office, Norwegian Industrial Property Office (NIPO), Turkish Patent Institute, Swiss Federal Institute of Intellectual Property, WIPO and a number of user associations. The latest CP6 Working Group meeting on the common practice of the requirements for graphic representation of designs took place on September 9 and 10, 2015. The next step for Convergence Project 6 (CP6) is to seek the acknowledgement and confirmation of the project results achieved so far by the 14th Liaison Meeting on Designs on October 13 and 14, 2015, at OHIM. In the next OHIM Administrative Board meeting in November 2015, the CP6 common practice, communication and implementation strategies will be presented for endorsement. Endorsement by the Administrative Board means that the project deliverables are supported by the Board and that the corresponding implementation procedures can be initiated by participating offices. In accordance with the Convergence Programme brief, participation in the Convergence Programme is completely voluntary – each office can implement the outcome of these projects once ready. More information on the Programme is available on the "European Trade Mark and Design Network" website at: <https://www.tmdn.org/network/web/10181/57>.

20. The International Bureau analyzed legal texts, including national laws, regulations and examination standards of some Contracting Parties with an Examining Office, together with the notifications of refusal sent to the International Bureau from the Korean Intellectual Property Office (KIPO)¹⁰. Furthermore, information regarding the examination practices has been provided to the International Bureau through informal consultations between Examining Offices and the International Bureau.

21. Finally, while the recommendations provided in the draft Guidance are not intended to cover all possible aspects of an appropriate disclosure, each Contracting Party is expected to clarify what recommendations are effective or acceptable to its Office. To that end, the fifth session of the Working Group is invited to comment on the contents of the draft Guidance, as contained in the Annex hereto, and on how to make it publicly available, such as posting it on the WIPO website, and how to manage and update it where an Examining Office changes its examination policy.

22. It should be noted that the said recommendations would not be legally binding on the Offices. Furthermore, it is stressed that even if the applicants were to follow the recommendations, the designated Office could still refuse protection pursuant to Rule 9(4) of the Common Regulations, on the basis of a substantive ground in accordance with its applicable law.

23. Finally, it should be noted that this exercise is limited to assisting the applicants in filing international applications, and it is not intended to harmonize the practices of the Offices or the legislation of the Hague Union members.

24. The Working Group is invited to comment on the contents of the draft "Guidance for Users of the Hague System Concerning Effective Measures to avoid Possible Refusals by Examining Offices on the Ground that an Industrial Design that is the Subject of an International Registration has not been Sufficiently Disclosed", as contained in the Annex hereto, and on the ways on how to make the Guidance publicly available, and further manage it.

[Annex follows]

¹⁰ At the time of preparation of this document, only KIPO among the Examining Offices had sent a relevant number of notifications of refusal to the International Bureau, since its accession to the 1999 Act in July 2014.

GUIDANCE FOR USERS OF THE HAGUE SYSTEM CONCERNING EFFECTIVE MEASURES TO AVOID POSSIBLE REFUSALS BY EXAMINING OFFICES ON THE GROUND THAT AN INDUSTRIAL DESIGN THAT IS THE SUBJECT OF AN INTERNATIONAL REGISTRATION HAS NOT BEEN SUFFICIENTLY DISCLOSED

Note 1: Even though an industrial design is registered as an international registration by the International Bureau of the World Intellectual Property Organization (WIPO), if the Office of a designated Contracting Party considers that the reproductions contained in the said international registration are not sufficient to fully disclose the industrial design, according to Rule 9(4) of the Common Regulations under the 1999 Act and the 1960 Act of the Hague Agreement, the effects of the international registration would be refused by the Office on such a substantive ground. There are mainly three situations where Examining Offices consider that the industrial design has not been sufficiently disclosed:

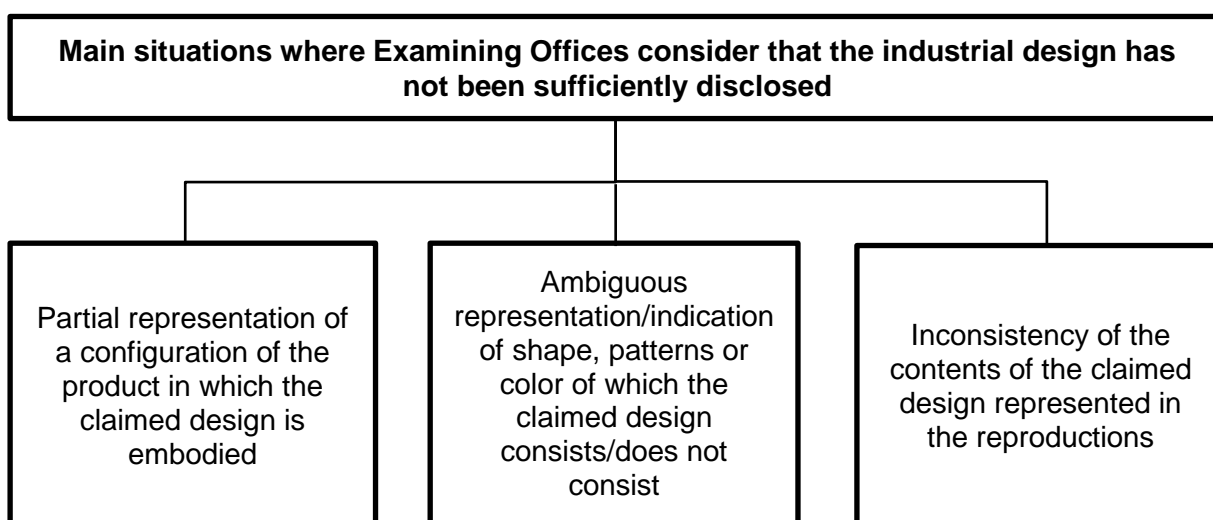

Note 2: It is important for the applicant to disclose the design sufficiently in the international application. Once the effects of the international registration are refused by the Office on the ground of failure to disclose the design sufficiently, the refusal cannot be overcome by requesting an amendment of the original representation by disclosing the parts which were considered ambiguous by the Office's examiner. That is to say, if the amendment were intended to add new matter to the original representation or to bring a change beyond the scope of identity of the design as originally disclosed, the amendment would not be accepted and the refusal would not be withdrawn by the Office.

Note 3: It should be noted that these recommendations are not legally binding on Offices. In other words, even if the applicants were to follow the recommendations, the Office could still refuse protection pursuant to Rule 9(4) of the Common Regulations, on the basis of a substantive ground in accordance with its applicable law.

RECOMMENDATIONS CONCERNING MEASURES TO AVOID POSSIBLE REFUSALS ON THE GROUND OF INSUFFICIENT DISCLOSURE OF AN INDUSTRIAL DESIGN

1. Not Enough Views

It would be considered by Examining Offices that the design has not been sufficiently disclosed if a whole configuration of the product in which the claimed design is embodied is not fully shown.

Typical Case Applicable

Only certain part of the product is shown in the reproductions without any explanation regarding the lack of some views.

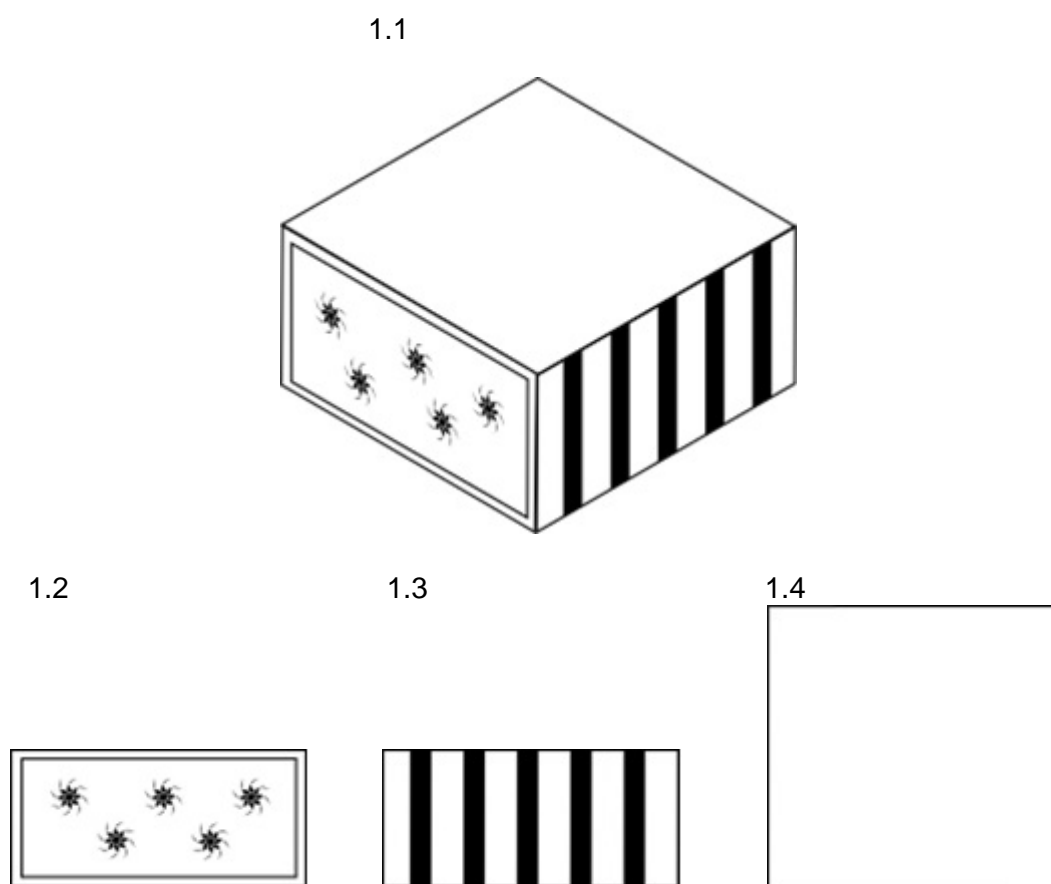

Recommendation 1.1: Provide a Sufficient Number of Views

- Six views of a three-dimensional product from different angles (front, back, top, bottom, right side, left side), or two views showing the front surface and rear surface of a two-dimensional physical product (e.g. postcard, textile, etc.) should be submitted¹.
- Instead of six views, perspective views may be accepted if the views show the entire configuration of the product.

¹ Where Japan is designated, those six views in compliance with the method of orthographic projection for a three-dimensional product should be submitted according to the declaration by Japan under Rule 9(3) of the Common Regulations.

- Each view should be of the same scale as the others.
- Appropriate legend or description indicating an angle of each view should be provided.

Best Mode Taking into Account the Recommendations

Six Views from Six Different Angles

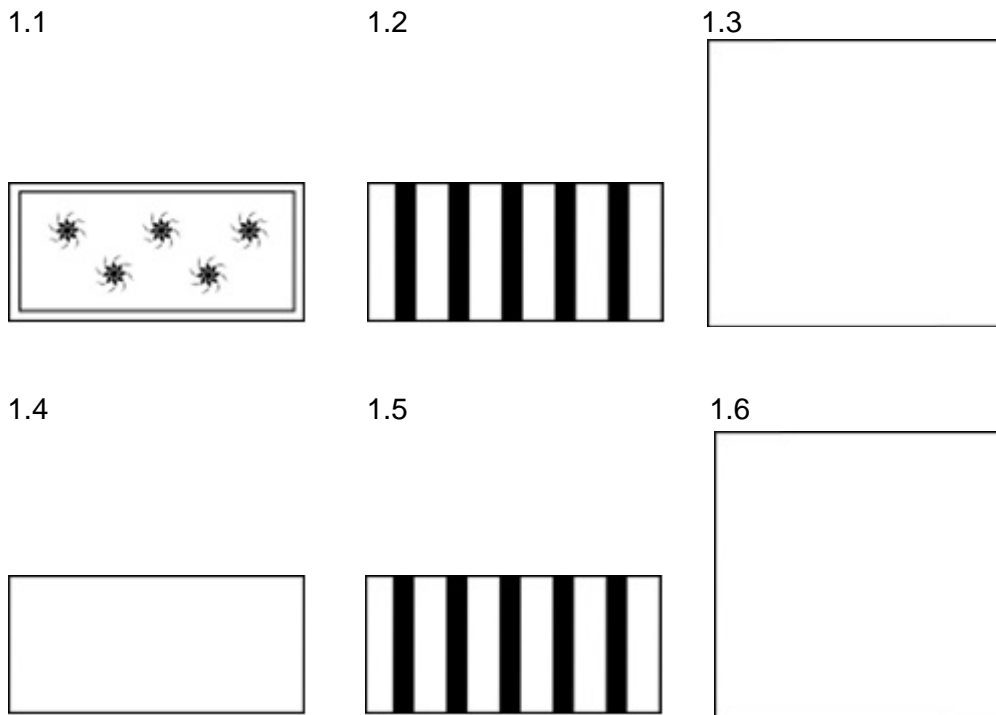

Legends/Description

1.1) Front view; 1.2) Right side view; 1.3) Top view; 1.4) Back view; 1.5) Left side view; 1.6) Bottom view

OR

Two Perspective Views Showing All Surfaces of the Product

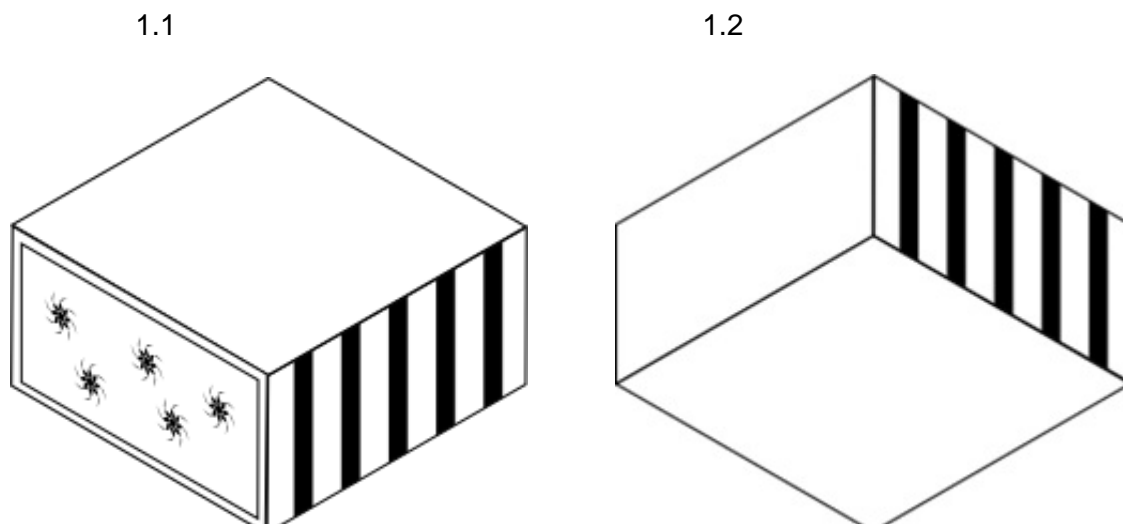

Legends/Description

1.1) Perspective view showing front, top and right sides of the product; 1.2) Perspective view showing back, bottom and left sides of the product.

Recommendation 1.2: Provide Explanations on the Omitted Views

Where the applicant wishes to omit a certain view(s) which is/are an identical or mirror image of another view² or which only shows a flat and non-ornamental surface of the product³, it should be clearly explained in the description which view(s) is(are) omitted and why that(those) view(s) is(are) omitted.

The view of one side and another view of the opposite side are identical

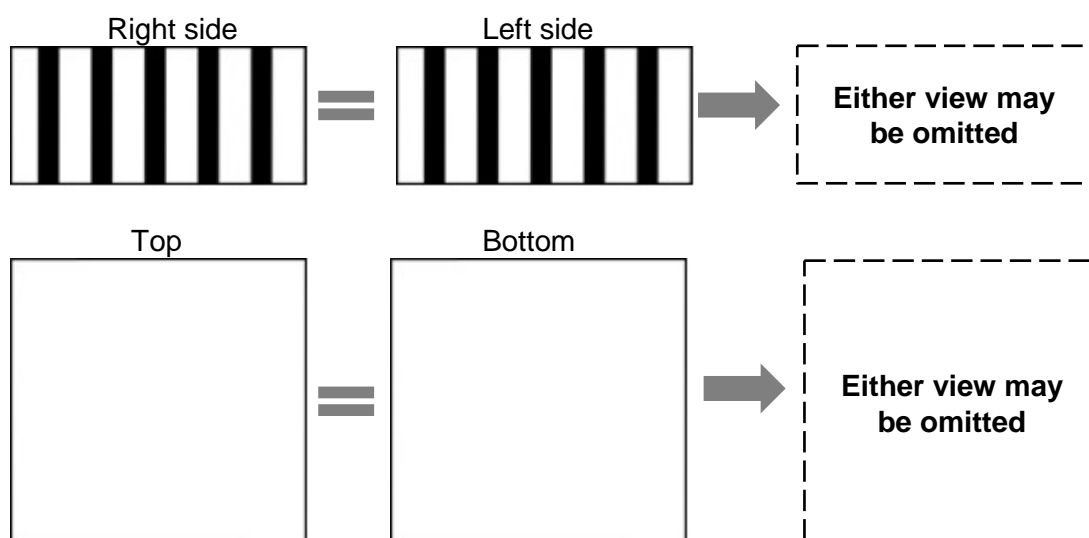

The view on one side has no ornamentation

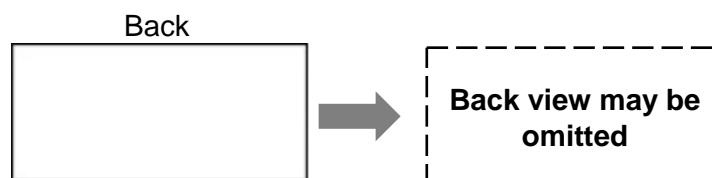

² In Japan, where front view is identical to back view, or top view is identical to bottom view, it is allowed to omit back view or bottom view.

³ In Japan, even if a certain view only shows a flat and non-ornamental surface of the product, it is not allowed to omit the view.

Best Mode Taking into Account the Recommendations

Three Views from Three Different Angles

1.1

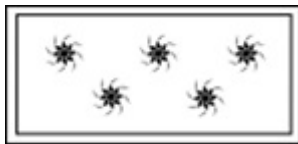

1.2



1.3

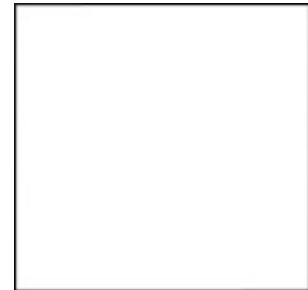

Legends/Description

1.1) Front view; 1.2) Right side view; 1.3) Top view

Description

A back view is omitted because the back surface of the product is flat and includes no ornamentation. The left side view and bottom view are omitted because they are mirror images of the views of their opposite sides (right side view and top view, respectively).

Recommendation 1.3: Provide Views Showing Disclaimed Part of the Product

Where an applicant seeks protection of a certain part of the product:

- the entire configuration of the product should be represented in six views or perspective views, even though protection is sought only for a certain part of it. In those views, the disclaimed part of the product must be indicated by means of dotted or broken lines or coloring, according to Section 403 of the Administrative Instructions for the Application of the Hague Agreement;
- an explanation on how the disclaimed part is indicated should be given in the description; if no explanation is given on how to identify the disclaimed part of the design, it could create an ambiguity in the sense that the dotted or broken lines may be considered part of an ornamentation on the surface of a product. Additionally, if the disclaimed part is indicated with coloring and no explanation is provided, the color would be considered as an integral element of the claimed design.

Best Mode Taking into Account the Recommendations

Six Views from Six Different Angles

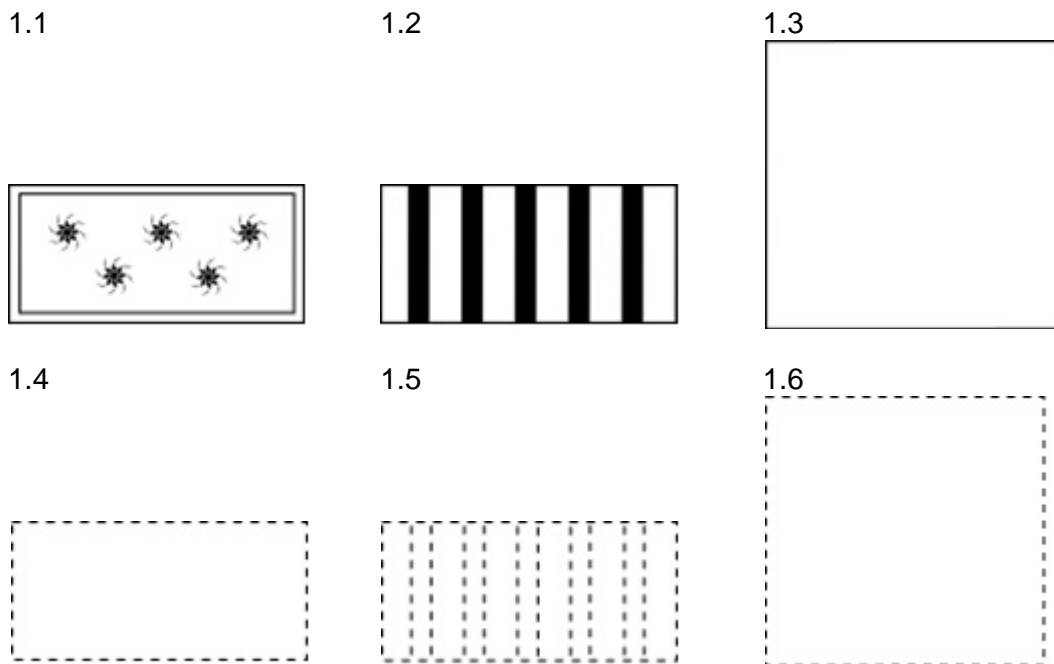

Legends/Description

1.1) Front view; 1.2) Right side view; 1.3) Top view; 1.4) Back view; 1.5) Left side view;
1.6) Bottom view

Description

The parts shown by means of broken lines in the reproductions are not part of the claimed design.

OR

Two Perspective Views Showing All Aspects of the Product

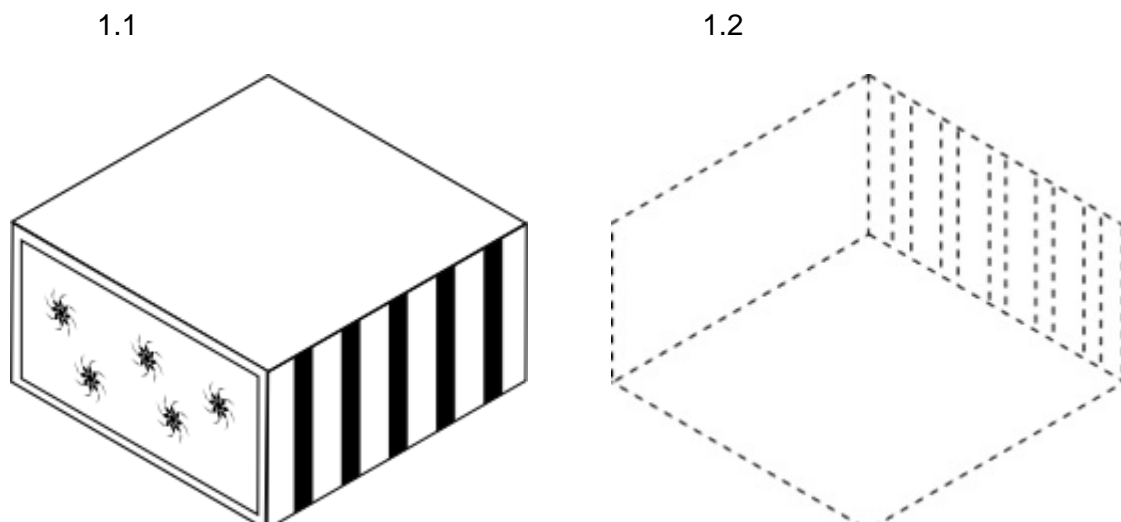

Legends/Description

1.2) Perspective view showing front, top and right sides of the product; 1.2) Perspective view showing back, bottom and left sides of the product

Description

The parts shown by means of broken lines in the reproductions are not part of the claimed design.

2. Ambiguous Representation of the Claimed Design

It would be considered by Examining Offices that the design has not been sufficiently disclosed if the scope of the claimed design has not been clearly defined with the submitted views only.

Typical Case Applicable

- Although the overall appearance of the product is represented in the reproductions, contours or configuration of a certain part have not been clearly disclosed.
- Where it seems that a certain part of the product is movable or may be opened and closed, the configuration of the said part which is not seen at a certain view angle has not been disclosed.

Indication of the product: “Storage box”

1.1

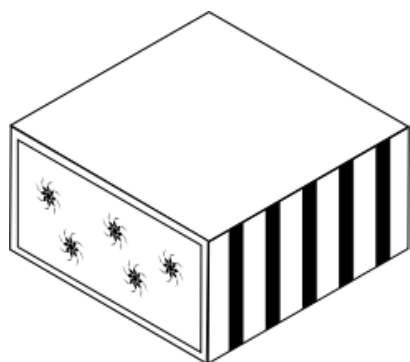

1.2

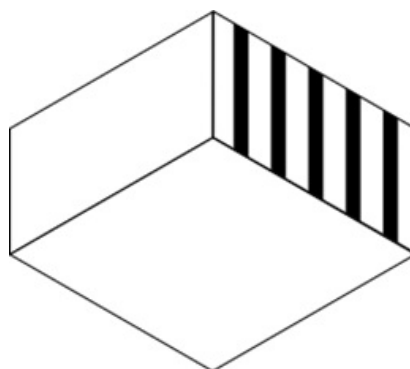

1.3

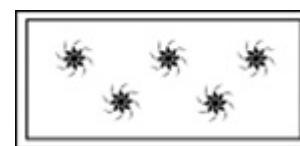

- Internal configuration is not clearly shown.
- Patterns on the front surface are not clearly shown.

Recommendation 2: Provide Supplemental Views

– Depending on the necessity of the clear disclosure of configuration of a certain part of the product, supplemental views such as (partially-) enlarged view, exploded view, cross-sectional view, view showing a state where the product has transformed, etc., in addition to standard views showing the appearance of the whole product (see Recommendation 1.1), should be submitted.

– An appropriate legend or description of the supplemental view should be provided to avoid any ambiguity. For example, the representations may be considered inconsistent with one another if a certain part of the product is represented largely in a view without an indication of “enlarged view” because the view is deemed to be different in scale from the other views.

– When an enlarged view or cross-sectional view is submitted, an indication of which portion of the product is shown in those views should be given in the description or in the corresponding legend.

Best Mode Taking into Account the Recommendations

1.1

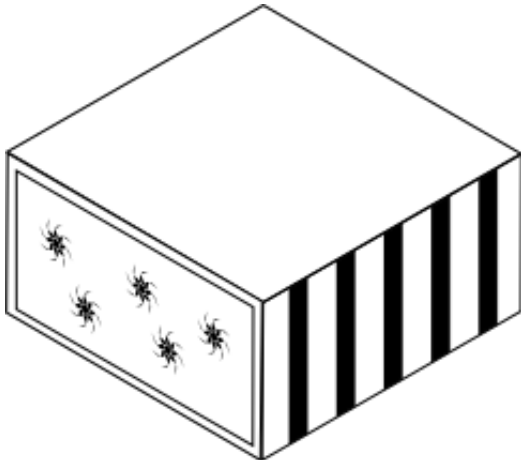

1.2

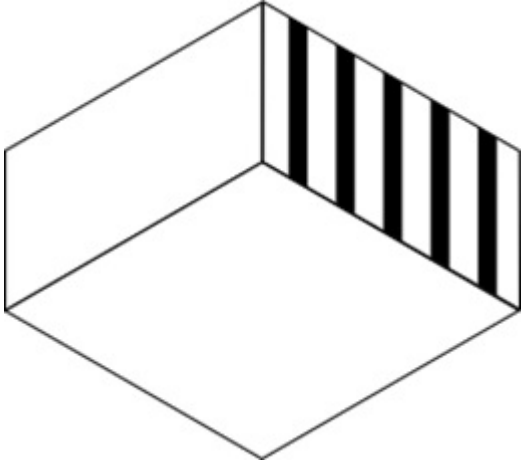

1.3

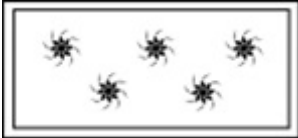

1.4

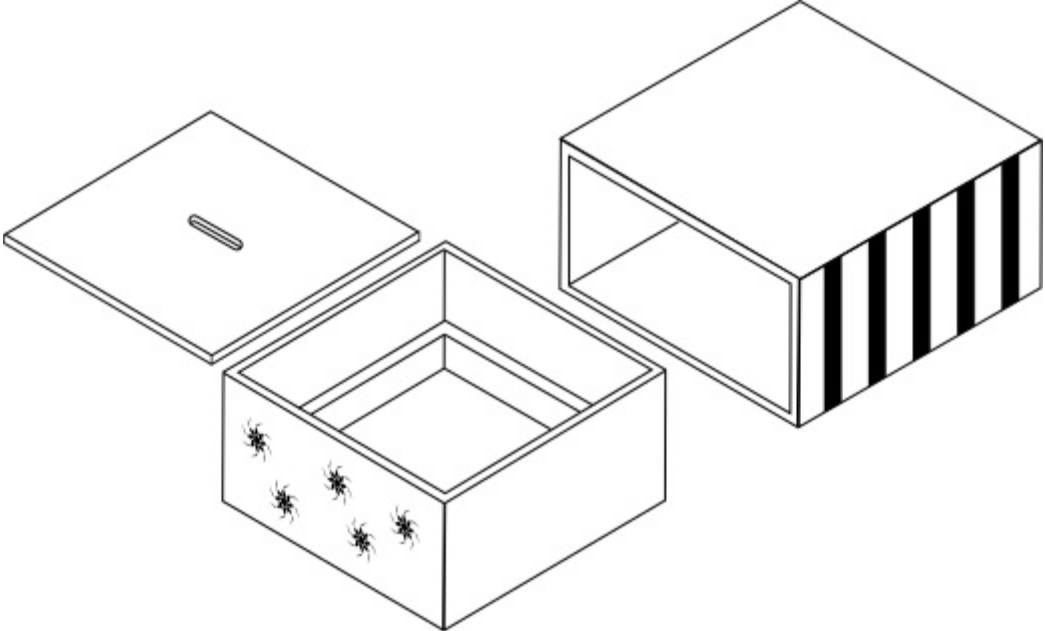

1.5

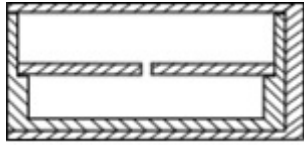

1.6

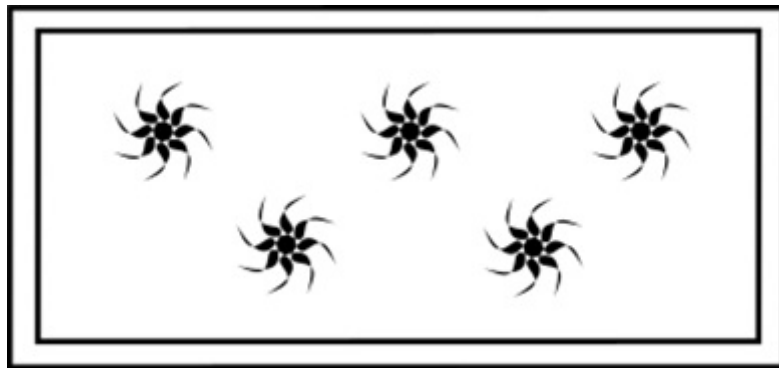

Legends/Description

1.1) Perspective view showing front, top and right sides of the product; 1.2) Perspective view showing back, bottom and left sides of the product; 1.3) Front view; 1.4) Exploded view; 1.5) Cross-sectional view of a middle part of the product from a right angle; 1.6) Enlarged front view.

3. Unclear Relief or Contours of Surfaces of a Three-Dimensional Product

It would be considered by Examining Offices that the design has not been sufficiently disclosed if the scope of the claimed design has not been clearly defined with the submitted drawings.

Typical Case Applicable

The contours of a three-dimensional product with curved surfaces have not been clearly shown in the representation since shading is not provided in the drawings.

DM/084919 – Indication of the product: “Perfume smelling strip holder”

If the lines indicate the contours of a surface of the product are not provided, the concrete contours of the product might not be clearly understood.

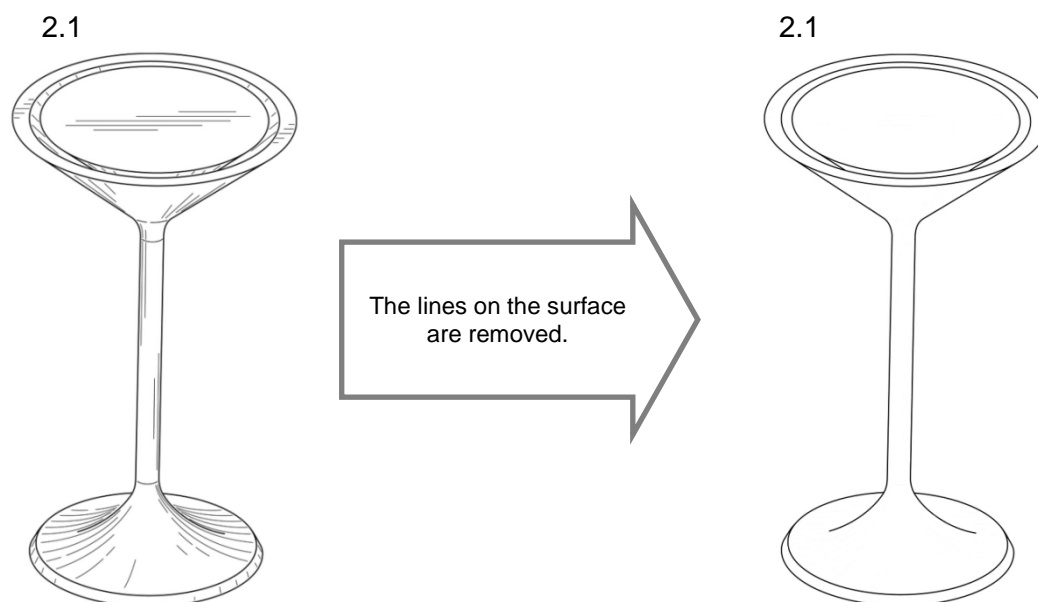

The image on the right was created by the International Bureau of WIPO based on the left image that is the original image of the view.

Recommendation 3: Provide Shading, Hatching, Dots, or Lines that May Be Used to Indicate Relief or Contours of Surfaces of a Three-Dimensional Product

– Shading, hatching, dots, or lines should be provided in the representations only where it is difficult to represent relief or contours of surfaces of a three-dimensional product without them⁴.

– The purpose of the shading, hatching or lines provided in the representations should be clearly stated in the description in order to avoid any confusion with patterns on the surfaces.

⁴ When Japan is designated, it should be noted that submitting sectional views or perspective views to represent relief or contours of surfaces of the product concretely is more preferable way than providing shading, hatching, etc. in the representation.

Best Mode Taking into Account the Recommendations

2.1



2.2

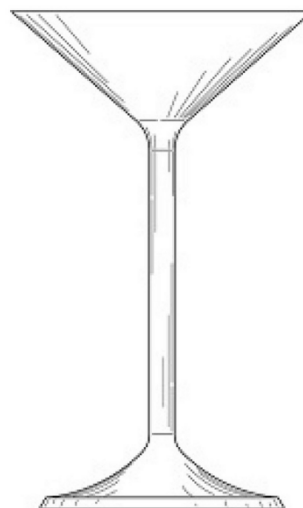

2.3

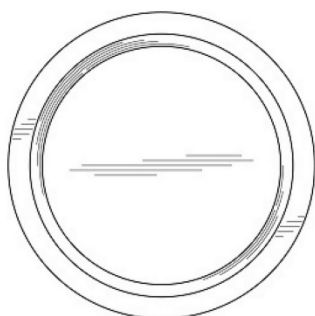

2.4

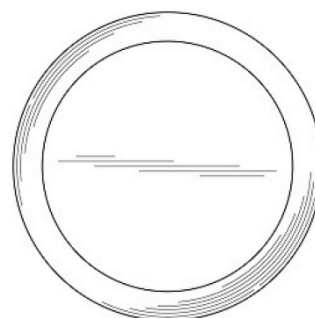

Legends/Description⁵

2.1) Perspective view; 2.2) Front view; 2.3) Top view; 2.4) Bottom view.

Description

The lines in the representation represent contours only and do not illustrate an ornamentation or decoration on the surface of the product. Left side view, right side view and back view are omitted because those views are identical to the front view.

⁵ Text of the above legends and description prepared by the International Bureau are not included in the original registration.

4. Difference in Form/Color Between the Reproductions/Representations of the Claimed Design

It would be considered by Examining Offices that if one (or some) of the reproductions are in different form or only one (or some) of the representations are in color, the contents of the claimed design shown in all the reproductions, such as color, pattern, etc., are inconsistent with each other.

Typical Case Applicable

– One (or some) of the reproduction(s) of an industrial design is(are) a photograph. The remaining one(s) is(are) a line drawing.

– One (or some) of the reproduction(s) of an industrial design is(are) a line drawing. The remaining one(s) is(are) a computer graphic representation.

– One (or some) of the representation(s) of an industrial design is(are) in color. The remaining one(s) is(are) in black and white.

1.1

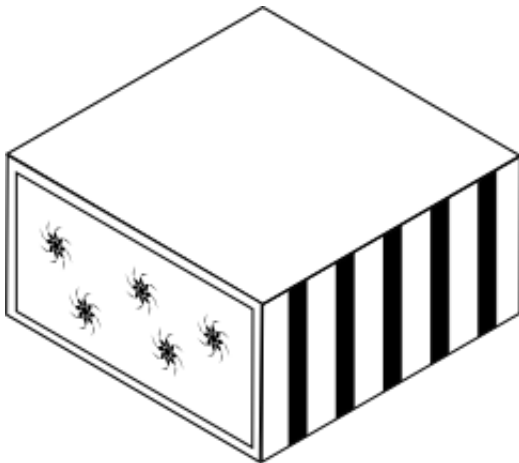

1.2

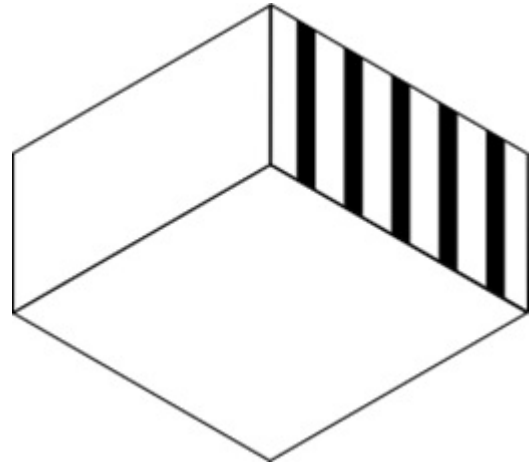

1.3

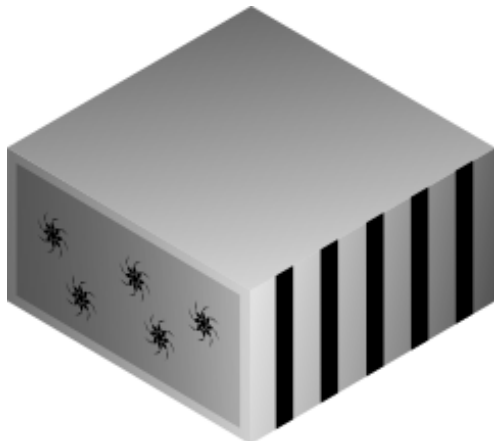

1.4

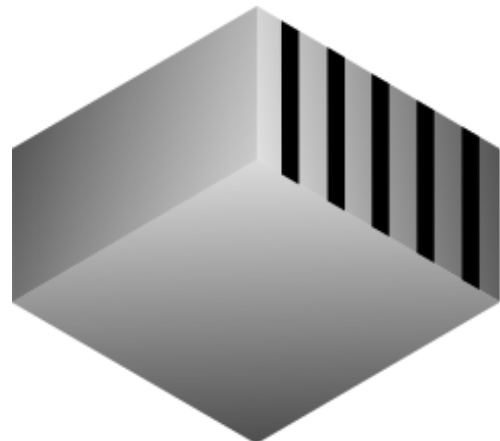

1.1 and 1.2 are line drawings while 1.3 and 1.4 are computer graphic representations.

Recommendation 4: No Mixing of the Reproductions in Different Forms/ No Mixing of the Representations in Black and White and in Color

- All reproductions should be in the same form⁶.
- Representations should be all in either black and white or color.

Best Mode Taking into Account the Recommendations

Design 1 is represented in the form of a line drawing and Design 2 is represented in the form of a computer graphic representation in the same application.

1.1

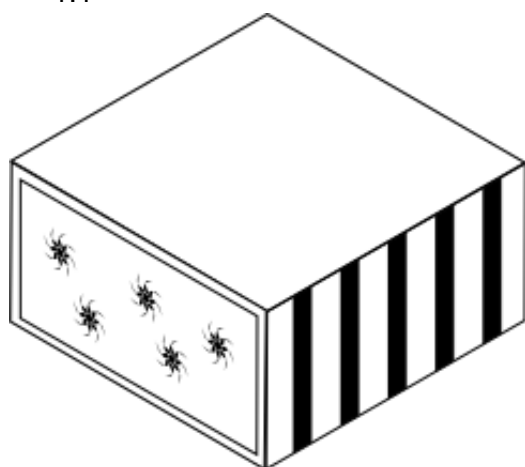

1.2

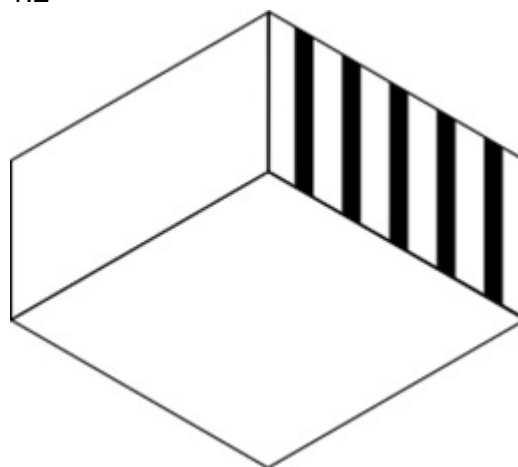

2.1

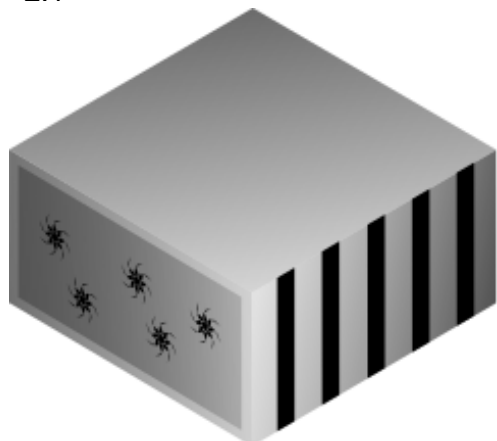

2.2

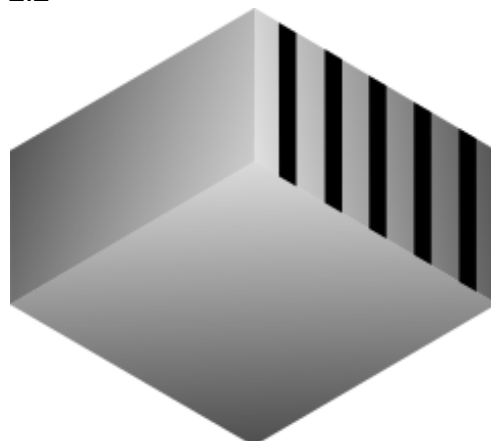

⁶ In Japan, mixing the reproductions of a design in different forms is accepted unless the examiner finds an inconsistency in color, pattern, or other elements of the design between those reproductions.

LIST SHOWING WHICH RECOMMENDATIONS SHOULD BE TAKEN INTO ACCOUNT WHEN DESIGNATING CERTAIN CONTRACTING PARTIES

Recommendations	Which recommendations should be taken into account when designating that Contracting Party?							
	HU	JP	KG	KR	MD	RO	SY	US
Recommendation 1								
Submit six views of a three-dimensional product or two views of a two-dimensional product		⊙		⊙				
Submit perspective views instead of six views		○		○				
Make all views to be in the same scale		⊙		○				
Indicate the angle of each view		⊙		○				
<i>In a situation where an applicant wishes to omit a certain view(s):</i>								
Explain which views are omitted and why they were omitted		⊙		⊙				
<i>In a situation where an applicant seeks protection of a certain part of the product:</i>								
Submit view(s) of a part(s) of the product for which protection is not sought, showing it by means of a disclaimer		⊙		⊙				
Explain the means to indicate the disclaimed part		⊙		○				
Recommendation 2								
Submit a supplemental view(s) for a clearer disclosure of the configuration of a certain part of the product		○		○				
Provide a legend of the supplemental view		⊙		○				
Indicate which portion of the product is shown in a cross-sectional or enlarged view		⊙		⊙				
Recommendation 3								
Provide shading, hatching or lines that may be used to indicate relief or contours of the surface of the product		○		○				
Explain the purpose of the shading, hatching or lines provided in the representation		⊙		○				
Recommendation 4								
No mixing of reproductions in different forms				○				
No mixing of representations in black and white and in color		⊙		⊙				

⊙ : Highly recommended ○ : Recommended

HU: Hungary; JP: Japan; KG: Kyrgyzstan; KR: Republic of Korea; MD: Republic of Moldova; RO: Rumania; SY: Syrian Arab Republic; US: United States of America

[End of Annex and of document]