

# WIPO MAGAZINE

FEBRUARY 2016

No. 1



Turn and face the strange:  
David Bowie and IP  
financial innovation

p. 10



Inside AZAM: one of Africa's  
top brands

p. 12



Protecting IP beyond the  
network with trade secrets

p. 22

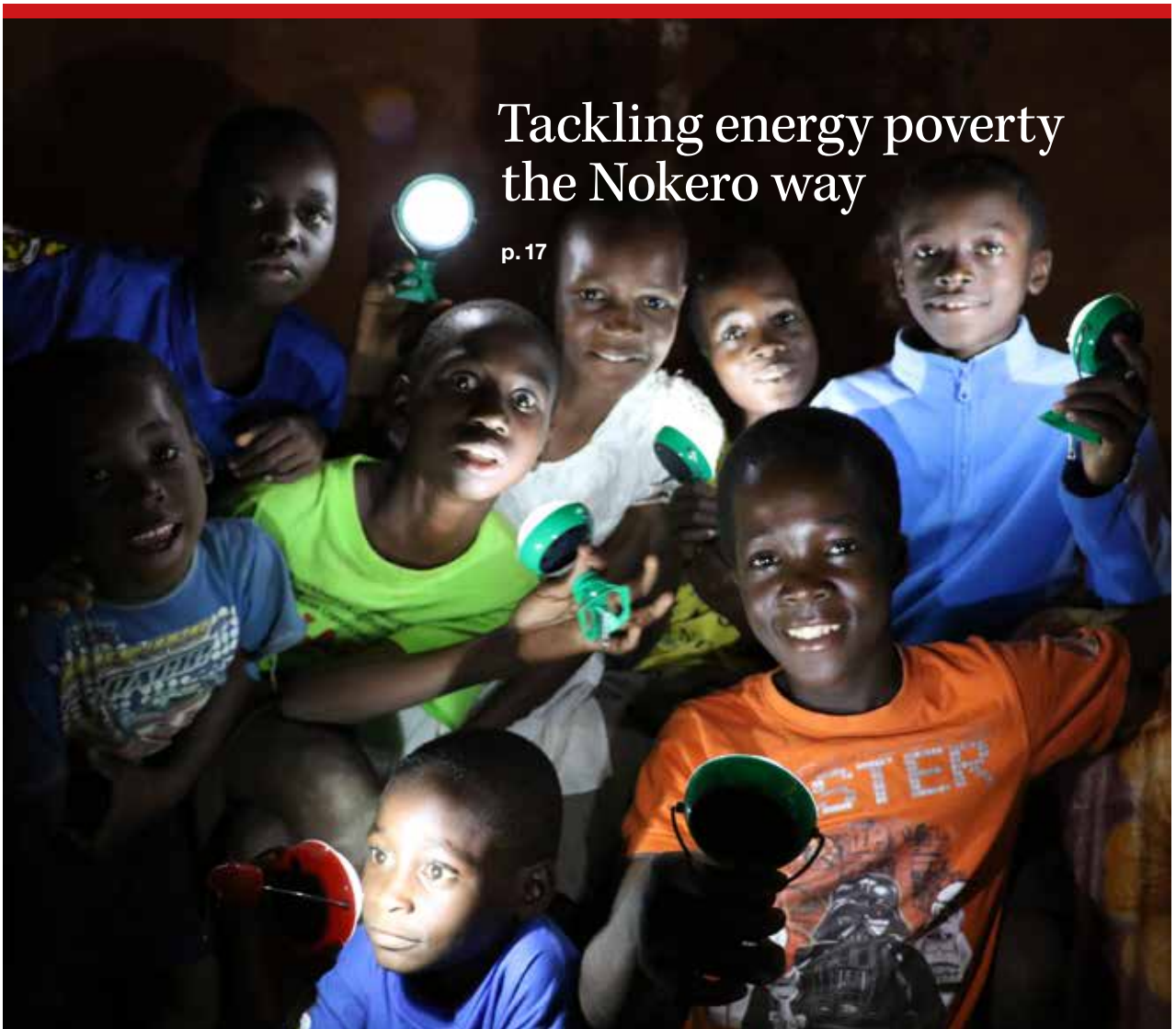

Tackling energy poverty  
the Nokero way

p. 17



# Table of Contents

2	Changing global disease patterns and the need for medical innovation
6	Intellectual property, finance and economic development
10	Turn and face the strange: David Bowie and IP financial innovation
12	Inside AZAM: one of Africa's top brands
17	Tackling energy poverty the Nokero way
22	Eight steps to secure trade secrets
26	Selling ideas – the future of jobs
30	Five tips for managing your patent assets
34	<i>In the courts:</i> Court confirms legal status of <i>Happy Birthday to You!</i>

Editor: **Catherine Jewell**  
Graphic Design: **Annick Demierre**

## Acknowledgements:

2	<b>Anatole Krattiger</b> and <b>Thomas Bombelles</b> , Global Challenges Division, WIPO
6	<b>Carsten Fink</b> , Economics and Statistics Division, WIPO
22 and 30	<b>Marco Aleman</b> , Patent Law Division, WIPO
34	<b>Miyuki Monroig</b> and <b>Paolo Lanteri</b> , Copyright Law Division, WIPO

Cover images:  
Left to Right: Thierry Ehrmann,  
via Flickr WIPO/Edward Harris,  
iStockphoto/alexsl  
Main image: Nokero Intl., Ltd.,

© World Intellectual  
Property Organization

# Changing global disease patterns and the need for medical innovation

By **Catherine Jewell**,  
Communications Division, WIPO

Dr. Peter Hotez is an internationally recognized expert in neglected tropical diseases (NTDs) and vaccine development. Among many roles, he is President of the Sabin Vaccine Institute in Houston, Texas, USA, (one of over a hundred members of WIPO's global health initiative, WIPO Re:Search), and founding dean of the National School of Tropical Medicine. In 2015 he was appointed by the State Department as US Science Envoy.

Dr. Hotez reveals how NTDs are a massive problem not just in the developing world but also for developed countries, and explains how scientists and policy makers – and WIPO – can work together to eliminate some of the world's most debilitating diseases.

## ***What are neglected tropical diseases?***

The concept of NTDs was established after the launch of the 2000 Millennium Development Goals. At the time, HIV/AIDs, malaria and tuberculosis were priority action areas, but given the huge health burden caused by parasitic diseases, my colleagues and I led global efforts for a cluster of the most common, chronic and debilitating conditions to be recognized as NTDs. Our aim was to draw attention to the human suffering these diseases cause and to attract funding for the development of new, more effective therapies to treat them.

Today, the NTDs include at least 17 chronic parasitic and related infections recognized by the World Health Organization. Almost everyone living in poverty has at least one of them. NTDs are diseases of poverty, of social stigma and of conflict. I often say that they are a reason why the bottom billion cannot escape poverty.

## ***What progress has been made in treating NTDs?***

Over the last 15 years we have made a significant impact through the use of “rapid impact packages” of low-cost generic drugs or drugs donated by multinational pharmaceutical companies, for example Zithromax (Pfizer), Ivermectin (MSD) and Praziquantel (Merck KGaA). We estimate around one billion people in low and middle-income countries have received this treatment so far. In some cases, we have matched achievements recorded for HIV/AIDs, malaria and TB and are on the point of eliminating trachoma, lymphatic filariasis, onchocerciasis and ascariasis. But similar progress has not yet been achieved for other NTD drug targets such as hookworm and schistosomiasis.

Despite these successes, the full impact of NTDs is still seriously underestimated. For example, NTDs account for a hidden burden of illness ordinarily attributed to the non-communicable diseases (NCDs). Take *Schistosoma haematobium* infection in Sub-Saharan Africa. According to a paper published in *Acta Tropica*, the eggs of the Schistosoma parasite are deposited in the bladder of 112 million people in Africa every day, producing 70 million cases of blood appearing in urine, 18 million cases of major bladder wall pathology, 9.6 million cases of hydronephrosis, 1.7 million non-functioning kidneys, one-third of all bladder cancers in Sub-Saharan Africa and 150,000 deaths from renal failure or bladder cancer. These diseases, however, are often classified as non-communicable renal diseases and not as NTDs.

Similarly, studies show that female genital schistosomiasis – possibly Africa’s most common gynecological condition, affecting tens of millions of girls and women – is one of the most important co-factors on the African continent for HIV/AIDS, and yet it is almost completely ignored.

Again, hookworm is the stealth cause of so much iron deficiency anemia in the world. The more worms an individual has, the greater the loss of intelligence. Studies show it can lead to a 40 percent reduction in wage-earning capacity. It is also one of the most common morbidities of pregnancy in Sub-Saharan Africa.

### ***What key challenges do you face?***

Perhaps the greatest challenge is ensuring that NTDs command the attention of policymakers so the necessary resources are available to fund the development of new treatments. The recent Ebola outbreak in West Africa was devastating and attracted much media attention, but it affected less than 0.1 percent of the population. So far, very little attention is being paid to the fact that most the population of the Ebola-affected countries suffers from at least one NTD schistosomiasis, hookworm and ascariasis, or dengue. This is an “inconvenient truth” that the world continues to ignore.

Poor understanding of the link between NTDs and NCDs such as diabetes, pulmonary heart disease and cancer, which are rising steeply in emerging economies, also poses a risk to funding for NTD drug research. While lifestyle changes are fueling increases in NCDs in emerging economies, many of these diseases are in fact caused by NTDs; for example, the link between schistosomiasis and renal disease highlighted above, but also Chagas disease and heart disease, paragonimiasis and lung disease, clonorchiasis/opisthorchiasis and cancer – the list goes on.

The prevalence of NTDs is widespread in sub-Saharan Africa but paradoxically, most of the world’s NTDs are found among the poor living in wealthy countries, that is G20 countries and Nigeria. In the United States, for example, we estimate that more than 10 million Americans living in poverty are infected with at least one NTD. Along with HIV/AIDS, malaria and TB, NTDs disproportionately affect the poor. Poverty is without doubt an overriding determinant of NTDs regardless of where they occur, including better-off nations, a phenomenon I call “blue marble health”.

The vulnerable populations in blue marble health countries (the G20 and Nigeria) are getting a double hit – from NTDs and from NCDs. In fact, we are now seeing

new co-morbid states emerging. In India, for example, high rates of dengue superimposed on diabetes are producing a unique co-morbid syndrome that requires new treatments. Another example is melioidosis and NCDs.

Blue marble health has important policy implications. The prevalence of NTDs in wealthy countries means tackling them is not a resource issue but an allocation issue. It means these countries will need to take greater responsibility in supporting the development of new NTD medicines. WIPO Re:Search, established to catalyze new research and development for NTDs, is particularly well positioned to make a difference in this space.

### ***Why should policymakers take blue marble health seriously?***

Governments now recognize that health has far-reaching economic and security implications. The recent Ebola outbreak was massively destabilizing for many governments, so in the end I think enlightened self-interest will push NTDs up the political agenda.

We cannot wait for catastrophic epidemics to happen and only then start making vaccines. We need to start anticipating the threat. Had a vaccine for Ebola been available earlier we could have prevented thousands of deaths.

### ***Why was there a delay in producing an Ebola vaccine?***

It was delayed because the vaccine was built using an outdated drug development model. Papers on the Ebola vaccine were first published in 2003, but the technology didn’t move because the business model is broken. Typically, scientists make a discovery and license it to a big pharmaceutical company which will produce it, but only if a viable market exists. Only when the US government put up funding to accelerate development of the Ebola vaccine through the Biomedical Advanced Research and Development Agency (BARDA) did it become available, and in record time.

We need to think differently about drug development. Pharmaceutical companies are always going to play a critical role. They have enormous expertise and a proven track record. We are always going to need them. But we also need to start thinking about broadening the field. We need to bring in new players like product development partnerships (PDPs) and developing country pharmaceutical companies to help advance medical innovation and global access to healthcare.

### ***What role do Product Development Partnerships play?***

PDPs emerged in the late 1990s to develop products for diseases affecting those living in extreme poverty. PDPs use industry approaches and practices, but operate as non-profit organizations and have successfully developed innovative methods for identifying drug leads and product development programs.

In 2000, I created a PDP at the Sabin Vaccine Institute to create the first human hookworm vaccine, which is currently in clinical trials. Today, the Sabin Institute is developing a portfolio of vaccines, including for schistosomiasis, onchocerciasis, Chagas disease and leishmaniasis ([www.sabin.org/programs/vaccine-development](http://www.sabin.org/programs/vaccine-development)).

PDPs can make the technologies needed to tackle NTDs upfront in response to public health needs rather than market forces. By supporting them and public-private partnerships like WIPO Re:Search, there is an opportunity to better anticipate and manage global health needs.

### ***Where does WIPO Re:Search fit in?***

Since it began in 2011, WIPO Re:Search has achieved some important successes. In particular, it has demonstrated that intellectual property is not a barrier to early-stage research into NTDs, malaria and TB. Since its inception, Bio Ventures for Global Health (BvGH), the WIPO Re:Search partnership administrator, has facilitated over 100 research collaborations among WIPO Re:Search members, which include many of the world's leading pharmaceutical companies and medical research institutes.

The type of international collaboration among scientists that is being actively fostered through WIPO Re:Search is a critical element in building global drug, diagnostic and vaccine capacity. In fact, how we collaborate and scientifically develop new antipoverty vaccines is as important as the vaccines themselves. Supporting the development of new products to treat NTDs in endemic countries helps ensure their availability to others in need elsewhere in the world.

WIPO has huge convening power and can bring key players to the table to shape the policies needed to foster innovation in the NTDs space. WIPO Re:Search is making a valuable contribution to global public health preparedness by helping to build – in collaboration with its partners, there is no value in working in silos – a pipeline of NTD research and development. WIPO Re:Search is already demonstrating its capacity to help fill the PDP

pipeline by catalyzing the discovery and identification of new product leads through its expanding global network.

I would also like to see WIPO Re:Search focus on exploring ways to support the development of innovative technology funds like the Global Health Innovative Technology (GHIT) Fund of Japan. Established in 2003, the Fund facilitates international partnerships that use Japanese technology and expertise to help alleviate the impact of infectious diseases. Innovative financing models are vital if we are to generate the funds needed to tackle these pernicious diseases.

The stark reality is that today we are facing a crisis in innovation. We are not seeing the level of innovation needed to tackle NTDs. So we need to think out of the box to find alternative ways to stimulate the development of new and improved technologies. There is certainly an important role here for WIPO Re:Search.

### ***Is there a role for the IP system in stimulating anti-poverty technologies?***

Protecting patents is a very labor-intensive, difficult and costly exercise, especially in the poverty-related diseases space. So it could be very useful if the systems for obtaining patent protection were cheaper and easier to use.

If I have hundreds of thousands of dollars, I do not want to spend it on foreign patent filings, I want to use it to hire scientists and to buy the equipment needed to make and test vaccines. So I think the cost of patenting needs to be looked at. I also think that sometimes organizations unnecessarily overinvest in IP. At the Sabin Institute, for example, we focus on publishing our results in open peer-reviewed literature. This eliminates the possibility of someone blocking our research. While this does not offer the same level of protection as that of a patent, it is a useful, low-cost defense strategy.

Going forward, we do have to be very clever about how we generate revenue from our technical ability to make medical products. The fact is our technical ability to create medical technologies has outpaced the social, political and financial innovations available to make them into useful products. That is why we need as much innovation in the area of economics and social and political sciences as we do in the biological and physical sciences. This is where an organization like WIPO has a comparative advantage because it has experience in this type of social innovation.



Photo: Sabin Vaccine Institute/Olivier Asselin

Ascariasis is the most common type of parasitic roundworm (above) infection affecting an estimated 1 billion people worldwide.



Photo: Sabin Vaccine Institute/Olivier Asselin



Photo: Sabin Vaccine Institute/Olivier Asselin

Neglected tropical diseases, which include at least 17 chronic parasitic and related infections, such as elephantiasis (left) and onchocerciasis (above) are diseases of poverty, of social stigma and of conflict. Almost everyone living in poverty has at least one of them.

# Intellectual property, finance and economic development

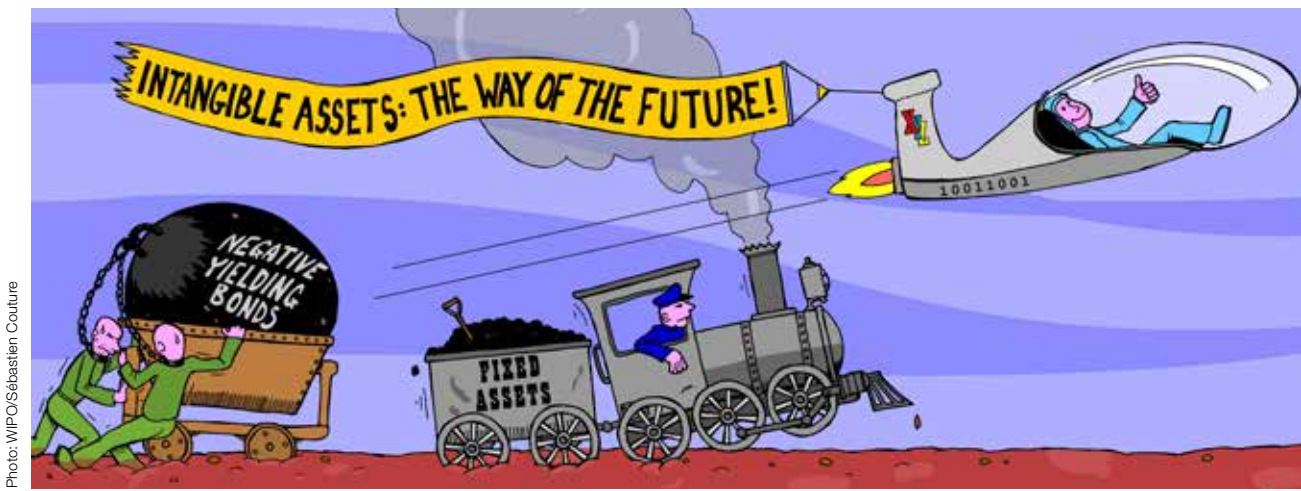

Photo: WIPO/Sébastien Couture

By **John P Ogier**, Intellectual Property Economist and Lead of the Finance, Business and Economics Sector Workgroup of the Intellectual Property Awareness Network (IPAN), London, UK, of which he is also Vice Chair.

Intellectual Property (IP) is now the most valuable asset class on the planet and yet establishing IP value and exploiting the economic potential of IP assets remain much of a mystery to businesses, financiers and investors.

The UK-based Intellectual Property Awareness Network (IPAN) is working to help get IP understood as a key asset class for business growth and economic development.

Only by developing and adapting market mechanisms and risk-return methodologies for IP assets and other intangibles and then applying them, will it be possible to offer IP-rich companies the financial support they need to expand their businesses and thereby improve economic growth. But progress in this area must involve financial markets, professional bodies, government policies and international trading standards.

## IP VALUE IN KNOWLEDGE-BASED ECONOMIES

In knowledge-based economies, economic value is captured through the IP system, and the rights it confers which transform intangibles into tradable economic assets.



Up to the 1980's, tangible assets accounted for 80 percent of company value; the rest was made up by intangibles, including IP. Thirty years later, the reverse is true with 80 percent of company value made up of intangibles.

The relative value of intangibles combined with digital trading is evident from the fact that Alibaba, the world's largest retailer, owns no stores; Uber, the world's largest "taxi business", owns no taxis; and iTunes only supplies digital recordings of music.

Research published in 2012 by the United States Patent and Trademark Office notes that "the entire US economy relies on some form of IP, because virtually every industry either produces or uses it." In 2010, IP-intensive industries accounted for USD5.06 trillion in value added, representing 34.6 percent of US GDP and directly supporting 27.1 million jobs.

Similar results were found in the UK where, according to a report by the UK IP Office, in 2011 the UK market sector invested some GBP137.5 billion in intangible assets and IP rights, with just GBP89.8 billion invested in tangibles. The gap in investments in tangibles and intangibles continues to widen.

The report indicates that just under half (48 percent) of knowledge-based investment – worth around GBP65.6 billion – is protected by IP rights. Copyright represents 46 percent of the total, trademarks and designs, 21 percent respectively, patents 9 per cent with registered designs making up the balance at 3 percent. The true value of UK IP-related investment, however, is likely to be higher as the study does not include the value of trade secrets nor does it fully account for "combination assets" like brands.

### THE GAP IN IP FINANCE AND FUNDING

Despite broad recognition of the economic value of IP and its contribution to economic growth, many start-ups face difficulties accessing affordable funds to expand their businesses. Many micro, tech/creative start-ups and small and medium-sized enterprises (SMEs) are IP rich and the life blood of a growing economy. However, in the aftermath of the economic crisis, these businesses continue to face a squeeze on capital, especially when seeking to finance the development of intangible assets.

Equity investors, from early stage funding to management buyout, see intellectual assets as a critical factor when evaluating prospective deals. But businesses, especially SMEs, generally rely on bank lending or asset finance to raise capital. Such financiers remain strongly focused on traditional assets (real estate, equipment,

inventories or receivables). Knowledge-intensive businesses, which have the greatest need of finance for growth, therefore often struggle to obtain funds because their intangible assets do not appear on the balance sheet and are therefore not considered by commercial banks as collateral.

With the application of reforms by the Basel Committee on Banking Supervision, banks are seeking additional security, even when government-backed schemes, such as the UK Enterprise Finance Guarantee scheme are available.

Without new solutions, it will be even harder for innovative companies, including creative digital enterprises, to obtain capital. These are precisely the types of high-growth enterprises that need to be financed to enable economic recovery.

### THE FUNDING CHALLENGE

IPAN flagged the funding gap facing IP-rich SMEs in 2012. Responding to these concerns, in 2013 the UK IP Office published a report on the role of IP and intangible assets in facilitating business finance. The report reaffirmed that mainstream lending practices rarely recognize IP or intangibles as collateral. Balance sheets do not represent the value of these assets, and current regulations actively work against recognition of IP and intangibles as an asset class.

### BENEFITS OF IP BACKED FINANCING

IP-backed financing offers significant benefits as follows:

- a) **Potential for value appreciation** – the IP assets of a well-run business increase in value over time, whereas the value of most tangible assets depreciates.
- b) **A wider pool of assets** – lenders often face situations where "good" customers want to borrow more than established asset lending ratios allow. The value that core intangible assets represent provides a means to lend more with additional security.
- c) **Stronger repayment incentives** – where intangibles are core to business activity, they provide a powerful incentive for borrowers to honor repayment commitments.
- d) **Improved security** – defining intellectual assets as part of a lending agreement puts a bank in a stronger position with an administrator in the event of financial difficulties.
- e) **Alternative to personal guarantees** – IP and intangibles provide an additional source of security that is directly related to a company and not an individual, thereby making it easier to recover funds if necessary.

## CHALLENGES

Overcoming the limitations and difficulties associated with current practice with regard to IP-backed financing does, however, present some challenges. These include:

- a) **Visibility of IP assets:** the significant investments in internally generated IP rarely appear on company balance sheets. Company directors need to understand and explain the value of their intangible assets in a language lenders understand and thereby provide a more representative picture of company resources and value.
- b) **Value attribution:** unquoted companies have no access to a market mechanism to measure the off-balance sheet value of their business. Whereas many tangible assets have a realizable disposal value, even if at a fraction of the original cost, the market for the resale of IP and intangible assets is underdeveloped and offers less certainty about the ability to realize any resale value.
- c) **Understanding value/managing risks:** the value of some intangible assets, such as brands, can change rapidly in line with company fortunes. Training and the adoption of recognized standards for intangible asset value management will give lenders greater confidence in managing the risk profiles associated with these assets.

## IP AND CAPITAL ALLOCATION

Notwithstanding the importance of intangible assets and their huge economic potential, a combination of factors – commercial trading practices, lending and risk criteria, accounting standards and financial regulations – means their true and fair value are not reflected in market mechanisms for allocating capital.

Current mechanisms for allocating capital were designed for the 20th century economy which was underpinned by the production of physical goods and services. The markets, regulations and investment return mechanisms for the intangible, technology-based assets of the 21st century are yet to fully materialize.

Greater transparency, as well as valuation methodologies and market mechanisms that are more attuned to the digital economy and that accurately measure and represent the risk and returns associated with intangibles are essential. Without them, innovative companies will continue to face restricted access to capital or will continue to pay a high price for it in terms of equity, security and interest.

## HARNESSING THE GROWTH POTENTIAL OF IP-RICH BUSINESSES

If the market for intangibles does not evolve, large quantities of capital will remain tied-up in low or negative yielding assets. In Europe, for example, government bonds worth between USD1.7 and USD5.3 trillion are yielding negative equity. The reallocation of just a fraction of this capital to finance IP-rich business could provide the much needed stimulus for global growth

and employment. For this to happen, various steps are needed, including:

- a) Company IP audits to provide a clear picture of the role IP plays in their business;
- b) Professionally accredited standards for IP valuation and risk management;
- c) Common platforms to advise and support banks and other investors in IP asset evaluation;
- d) Greater understanding of IP licensing as a means of enabling small businesses to grow rapidly and internationally without large-scale infrastructure investment;
- e) Active engagement of financial services industries in financing, insuring and structuring intangibles as an asset class;
- f) More accessible and effective IP marketplaces;
- g) Better access to IP training, including for the financial services sector;
- h) International standards for registering IP-related information of relevance to financial transactions.

### THE EVOLVING FINANCIAL IP ENVIRONMENT

The financial services sector is starting to wake up to the economic importance of IP and intangible assets but there is still some way to go. A seminar hosted by the Institute of Chartered Accountants, England and Wales (ICAEW) in February 2015 highlighted the increasing importance of IP in mergers and acquisitions in the global market. In November 2015, the Creative Industries Federation and ICAEW released their *Creative industries – Routes to Finance* guide. At the same time, a GBP40 million Edge Creative Enterprise Fund, backed by the British Business Investment Bank and the private sector, was launched.

Valuation methodologies for IP assets, including new regulation standards, are coming on stream but a standard methodology endorsed by accredited accounting bodies to assess the “true and fair value” of these assets is still needed. Brokerage services and marketplaces to facilitate sale and purchase of intangibles are also multiplying.

The commercial finance sector is also slowly responding to the needs of knowledge-based companies. More specialist lenders are now entering into sale and license-back agreements secured against IP assets, including trademarks and copyright-protected software.

The first transactions leveraging brand assets to address pension fund deficits have been completed with large organizations including Philips, GKN, Costain, Diageo, AA and TUI adopting creative structures that leverage IP and/or the income streams derived from it. Financiers taking equity positions are also electing to take a charge over software assets, protected by escrow arrangements.

The absence of international standards to provide greater clarity and certainty regarding charges or securitization of IP assets is putting a brake on investment and business loans that could otherwise be secured against these assets. Is there a role here for WIPO to facilitate the negotiation of such an international standard? IPAN thinks there is, because such information could readily be recorded by national IP offices along with other IP registration details.

### A WAY TO STIMULATE GLOBAL GROWTH?

The world is experiencing a crisis in economic growth that record low interest rates and quantitative easing have yet to resolve. Coupling the power and size of the financial services industries with the IP-protected intellectual capital of knowledge-based companies could be a part of the solution. A key factor in unlocking this potential is ensuring access to capital is eased for those economic units with the greatest growth potential, namely start-ups and SMEs.

All the key players from industry, financial services, professional bodies, educational establishments, governments and international organizations like WIPO will have to apply their respective skills and resources to realize this potential for economic growth and public good. That after all is why the IP environment was created in the first place.

# Turn and face the strange: David Bowie and IP financial innovation

By Edward Harris,  
Communications Division, WIPO

Glam rock, gender-bending costume changes, massive set-piece operas starring aliens fallen to earth ... and asset-backed securities.

David Bowie's endless energy for creative self-invention and musical innovation attracted worldwide fame, making him one of the most-admired performers of his generation. Less well known was his trailblazing role in the use of intellectual property (IP).

Bowie in 1997 sold USD55 million of what his representative termed "Bowie Bonds" – 10-year securities paying 7.9 percent, backed by 25 Bowie albums recorded before 1990. He aimed to secure a "higher advance than possible from [a] new distribution deal with [his] record company" and "to buy back publishing rights in some songs owned by a former manager and invest in internet companies," according to the original "Bowie Bond" prospectus.

"This was a creative, pioneering use of the copyright system – but it is not available to all creators, because many of them do not own all the necessary rights to their works, so securitization of future royalties is difficult, or the creators may not have access to the market for other reasons," says Michele Woods, Director of WIPO's Copyright Law Division. "That's why WIPO is working hard to help the world's creators boost their earnings in a number of ways."

## **BOWIE BONDS**

Bowie Bonds were the first in a line of financial instruments underpinned by creators' earnings, with followers including James Brown, Marvin Gaye and others. The bonds allowed artists to monetize their work immediately, handing them investment cash up front to diversify their portfolios or make other large acquisitions. Such securitization continues within the creative sector. A recent example, reported by *Variety* in 2014, is Miramax's USD250 million securitization of its 700-strong film library to support its television and film ventures.

## **BERNE CONVENTION, BEIJING TREATY**

Existing WIPO Treaties, including the Berne Convention for the Protection of Literary and Artistic Works, provide the framework for creators to monetize their creations, and WIPO member states



Photo by Thierry Ehrmann, via Flickr

David Bowie's endless energy for creative self-invention and musical innovation attracted worldwide fame. Less well known was his trailblazing role in the use of IP.

are working on new ways to benefit creators. In June 2012, WIPO member states adopted the Beijing Treaty on Audiovisual Performances, which grants performers four kinds of economic rights for their audiovisual performances, such as motion pictures. These include: the rights of reproduction, distribution, rental, and of otherwise making available their performance. The Treaty also grants performers moral rights, among other benefits to help creators, and covers music performances contained in audiovisual works such as films and television program.

It will take effect when 30 eligible parties have ratified or acceded to the Treaty – 20 more are needed, as of January 2016.

#### **AN EVOLVING LANDSCAPE**

Bowie himself foresaw how the Internet would cause changes in the distribution of artists' work, including illegal

downloads. In the end, ratings agencies downgraded the rating of the "Bowie Bonds," as torrent downloads became popular in the early 2000s, cutting into creators' earnings.

Now, with the rise in streaming services, such as Netflix, Amazon Prime, Spotify and Apple Music, a new vector for distribution is increasingly available to creators.

WIPO is helping to support artists during this technological transition through its normative work. In fact, World Intellectual Property Day on April 26, 2016 – with the theme of Digital Creativity: Culture Reimagined – will be looking at the opportunities and challenges arising from the emergence of a global digital content marketplace, with a high-level conference taking place at WIPO in Geneva a few days earlier.

# Inside AZAM: one of Africa's top brands

By **Edward Harris**, Communications  
Division, WIPO





AZAM, one of Africa's top brands, is now competing in the crowded sports and media space. The AZAM Football Club launched in 2004 is a cornerstone of the company's expanding content creation and distribution business.

On a blazing Saturday afternoon in Dar-es-Salaam, Tanzanians across this Indian Ocean port city munch on biscuits, bread and ice cream and beat the heat with cola and fruit juice. Boats steam out to sea, ferrying tourists to the island of Zanzibar. At Chamazi Stadium, a leading football team drives toward to the goal line as cameras beam the action to a nationwide TV audience.

It's a restful weekend scenario, held together by a common thread – AZAM. The snacks and drinks, boats, sports and broadcasting all bear the AZAM trademark, nurtured by a local Tanzanian company from humble beginnings into one of Africa's most important homegrown brands.

Now, its owner, the Bakhresa Group, is expanding AZAM across East Africa and Southern Africa. This is just the latest development of a trademark that was born in the 1970s in a street-side restaurant selling donuts.

For Abubakar Bakhresa, Executive Director and son of founder Said Salim Bakhresa, the AZAM odyssey holds lessons for entrepreneurs across Africa, and indeed across the globe, who seek to use trademarks to promote their products.

### **BUILDING A BRAND REQUIRES A LONG-TERM VISION**

“There are no quick answers to developing a brand; it's a challenge,” Mr. Bakhresa says. “But if you have a very long-term view, your business and your brand will succeed. You have to develop a brand that is not just encompassing your market. You have to have a vision that it can grow beyond your market. You have to believe in the brand.”

These days, a stroll through the bustling markets of central Dar-es-Salaam feels like walking through an AZAM corporate display case. Young men pedal tricycles mounted with AZAM-logoed refrigerators, from which they sell AZAM ice cream. Shop fronts display the wide range of AZAM products: bread, milk, pasta, flour, cola and other soft drinks. Bakhresa trucks transport AZAM goods between depots and restaurants, televisions connected to AZAM cable boxes show AZAM news programs, and AZAM commentators enthusiastically broadcast the fortunes of the AZAM football team.

The Bakhresa Group is now an industrial conglomerate with annual sales of over USD800 million and thousands of employees across East Africa.



Photos: WIPCO/ Edward Harris

The Bakhresa Group has grown from humble beginnings in the 1970s to become an industrial conglomerate with an extensive product range, annual sales of over USD 800 million and thousands of employees across East Africa. AZAM is its flagship brand.



## THE PRICE PLUS QUALITY CHALLENGE

But this wasn't always the case. Abubakar Bakhresa's father, Said Salim Bakhresa, began the company in the 1970s, selling baked goods and other comestibles out of a small restaurant. Reflecting Dar-es-Salaam's unique cultural mix as a trading center on the Indian Ocean, AZAM is derived from Arabic and Urdu terms meaning "great".

The current logo, which resembles a wave, came later. But the AZAM name has persisted through the company's rapid growth. This, Mr. Bakhresa explains, is because the public perception of the mark converged with the company's focus on quality and price, which are key in a country like Tanzania.

"When people came to Africa, they thought the people do not require quality, that they require price. But we managed to get the correct mix – we match quality and price and that has been the success of the brand," he says. "To achieve that is a challenge."

Two linchpins of the AZAM brand's success are large markets, which allow for economies of scale and lower prices, and a strong grip on the entire production process, which promotes quality. The Bakhresa Group invests heavily in state-of-the-art milling, processing and packaging equipment to produce high-quality goods.

## FROM TRADEMARK TO TOP BRAND

The Group finally took steps to protect the AZAM trademark in 1999, as it began expanding its product line and looked toward entering overseas markets. "At that time the family business was growing... and we felt that it was the right time to make AZAM the flagship brand," says Mr. Bakhresa. "The vision was always to become a pan-African brand."

Protecting your trademark at home is a key step to overseas expansion, says Leonila Kishebuka, Deputy Registrar at the Intellectual Property of Tanzania's Business Registrations and Licensing Agency.

Opening the file containing the original application for the AZAM trademark, Ms. Kishebuka says that a strong trademark is particularly important in less-developed

and very diverse markets in which many languages are spoken and consumers seek symbols to help them choose the correct product.

"To the consumers it is a way to identify the best quality product they want to purchase from the market," she says. "You cannot just go to the shop and say that I want milled maize flour, you just mention the brand and then you get it. So it is very important to consumers for identification purposes."

The AZAM brand is now one of very few East African brands to join Apple, Samsung, Google, Microsoft and Coca-Cola on the list of Africa's 100 most valuable brands in 2015, according to a survey by Brand Africa.

That brand value has real economic implications, explains Mr. Bakhresa. Because AZAM is so well known, the company can launch new products without splashy – and costly – marketing and public relations campaigns.

"That's the success of the brand. It has evolved and we don't even need to do much marketing. The day we launch a new product with an AZAM name, immediately, people associate it with quality, price, affordability, and expect that," he says. "We accept that challenge."

## SCORING NEW BUSINESS SUCCESSES

Competing in a crowded sports and media space is the latest test for the AZAM brand. In 2004, the Group launched the AZAM Football Club, in response to the preponderance of foreign football available on satellite and other television services, Mr. Bakhresa says. The team is now an anchor of the company's expanding business in content creation and distribution. "The football club was what actually triggered the growth of the media business," he explains.

In new studios on a main road leading out of Dar-es-Salaam, past one of the company's flour-milling factories, AZAM producers are wrapping up post-game coverage of the day's match. On a sound stage, a young female announcer in a headscarf banter with her male colleague in Swahili, Tanzania's *lingua franca*. The evening newscast is being prepared. Advertisements for AZAM roll – all carried into viewers' homes by AZAM-emblazoned receivers.

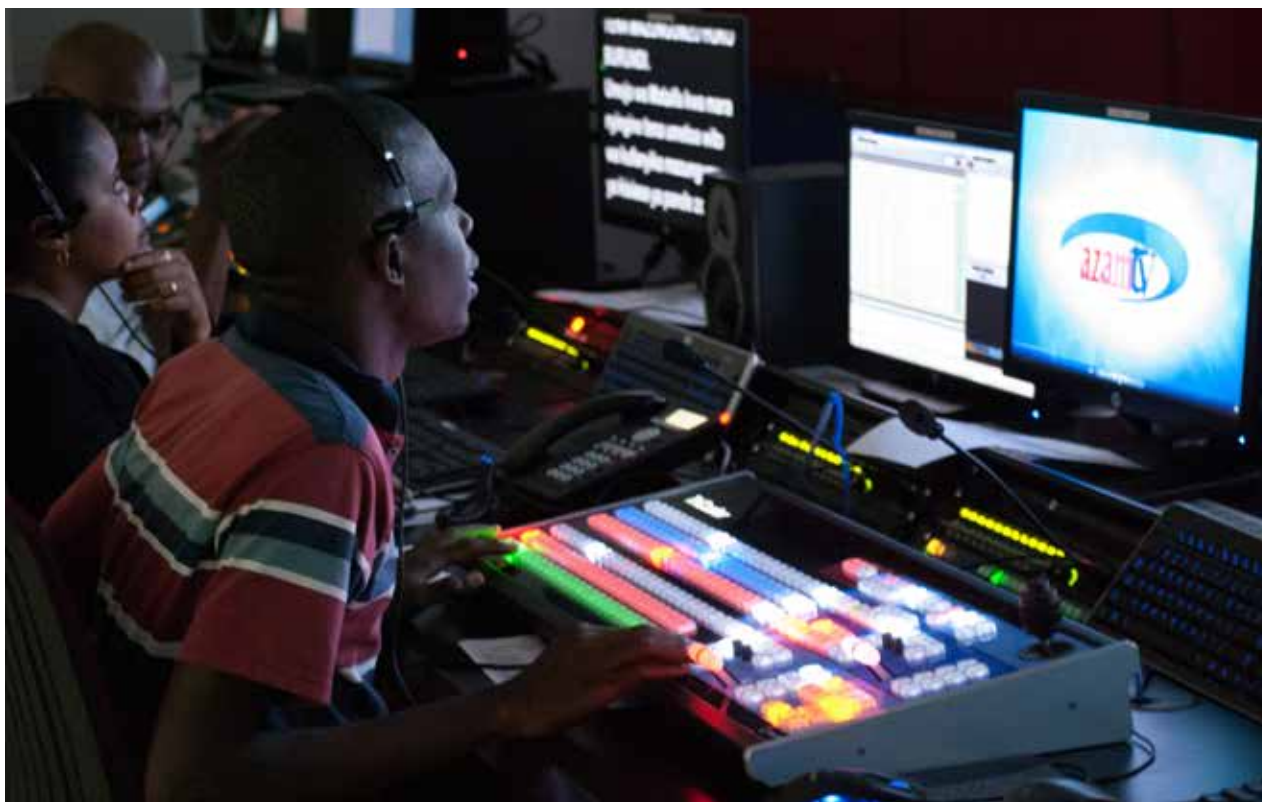

Photo: WIPO/Edward Harris

The transformation of the AZAM brand from baked goods to modern telecommunications is well underway.

So, the transformation of the AZAM brand from baked goods to modern telecommunications is well underway – and there are lessons for other companies looking to expand their brand, Mr. Bakhresa says.

“You have to realize that whatever business is attached to that brand has to succeed and you have to do things correctly. And if your view is maybe just five years or ten years, your brand is not going to develop.”

#### **SUPPORTING TANZANIA'S ECONOMY**

For Mr. Bakhresa, strong businesses can promote national development in countries like Tanzania.

“For us, our dream is to make sure that we have more people like us, who are sincere about their business, who want to develop their products, who are there for the long-term, are keen to develop their economies, make sure that you have more entrepreneurs and develop a middle class with more purchasing power – and with governments that are there to support their private sector,” he says.

“If you have that and you have more people like us, if you have more AZAMs out there, I think we have a good chance in Africa, we have a good chance in Tanzania, to reduce poverty and improve the standards of living. I think we are going to go far.”

# Tackling energy poverty the Nokero way

By **Catherine Jewell**,  
Communications Division, WIPO

One in five people (some 1.3 billion people) still live without access to electricity. Many rely on kerosene, an expensive poor-quality and polluting lighting source, to illuminate their homes at night. For the past six years, Steve Katsaros and his team at Nokero – which stands for “no kerosene” – have been tackling energy poverty. By developing and distributing low-cost, eco-friendly solar-powered lights, US-based Nokero is transforming the livelihood opportunities of resource-poor households in developing countries. So far Nokero has distributed over 1.4 million lights across 120 countries. In October 2015, the company launched its latest innovation, the N233, which has been billed as “the most efficient light bulb in the world”.

Nokero was a 2013 winner of the *Patents for Humanity* competition run by the United States Patent and Trademark Office (USPTO), which recognizes patent owners and licensees for their efforts in addressing development challenges.

Nokero’s founder, Steve Katsaros, explains how he came to set-up the company and the role intellectual property (IP) rights play in enabling it to provide a more sustainable alternative to kerosene lamps.

## ***What prompted you to set up Nokero?***

I was practicing patent law in the United States as a US Patent Agent at Cochran Freund & Young LLC and happened to come up with the original version of the solar light bulb. At first, it was just a product idea with no particular ambition to solve energy poverty, but within four days I realized this was the solution for the 1.3 billion humans living without electricity. From that point, the entire product and business was aligned with bringing light to the furthest reaches of the globe.

## ***Can you outline some of the negative impacts of kerosene lighting?***

Where to start! To begin with, the poorest people in the world are spending around 20 percent of their income

(totaling some USD30 billion per year) on kerosene for lighting – a practice that limits their ability to invest in education, agriculture and improving their dwellings. Those who burn kerosene because they do not have access to electricity are vulnerable to injury and death by fire. The risk of fire-related deaths increases by a factor of eight when using kerosene. Kids also accidentally drink kerosene, which is commonly transported and stored in discarded soft drinks bottles. The carbon emissions associated with burning kerosene have also been directly linked to climate change.

## ***Why did you opt for the social entrepreneurship model?***

When I started Nokero, I explored both the non-profit and for-profit models. After some thought, I decided the for-profit path was more aligned to my entrepreneurial beliefs. While I wasn’t familiar with terms such as “social entrepreneur”, “impact inventor” and “triple bottom line”, I knew that profit attracts scale, and bringing a safe and affordable source of light into people’s lives meant we needed to scale things up as fast as possible. So my primary goal was to create a company. Its brand was our mission – “no kerosene”. Just six days after we launched, our story was picked up by CNN’s reporter Ali Velshi and that sent us into orbit.

## ***How is the company funded?***

Nokero is funded privately by a group of investors. Our biggest markets are in Southeast Asia and Africa, but we are seeing strong growth in Central and South America. So far we have sold some 1.4 million solar lamps in 120 countries.

## ***What impact are Nokero lamps having on resource-poor households in developing countries?***

Our lamps are expanding the livelihood options of people in resource-poor households. So far, by replacing kerosene lamps, we have been able to greatly improve

the safety and financial situation of around seven million people. Our sector generally believes that five people benefit from every solar lamp that is distributed.

Let me give you a few examples from among those millions of people.

Etienne Ellisime, who lives in Les Anglais, Haiti, is a rent-to-own customer. She was able to save 5 Haitian Gourdes (HTG) (equivalent to USD0.12) per night using a Nokero light instead of kerosene to illuminate her small house. In one year she saved over USD40. She likes the lamp because in addition to saving her money, it is brighter, cleaner and safer than kerosene.

Mpisi Melusi Ndlovu, who comes from a village near Victoria Falls in Zimbabwe, has provided lamps to children in his community. They no longer have to share a single candle between them but can now study for four hours after dark.

And Agatha NyaNyapoloto in Swaziland has been using her Nokero lamp for years to do her daily chores at night and to socialize with neighbors who don't have electricity.

***How do you get your bulbs out to those that need them?***

We have two specific pathways for distributing our light bulbs: AID-channels and PAID-channels. With AID-channels, the lights are purchased on behalf of the people who need them but cannot afford them, for example, through philanthropic outfits or non-governmental organizations. Our PAID-channels cover traditional reseller networks where everyone in the supply chain receives a margin. Our lowest cost product retails at USD5.99 and the most popular lamp retails for USD14.99. The wholesale price is roughly half the retail price.

***What role does intellectual property (IP) play in the company?***

Patents are a big part of our business strategy. As a US Patent Agent, I have paid close attention to protecting our IP. For example, we put a great deal of effort into developing the functionality and design of our products. Design and utility make a product, and a successful product requires both. So at Nokero we use both design and utility patents to protect our products. When you start out with product design, you do not know what will be patentable, so it is best to pursue protection for both, although each type of right does have its own unique benefits. It really depends on your business strategy and your long-term goals.

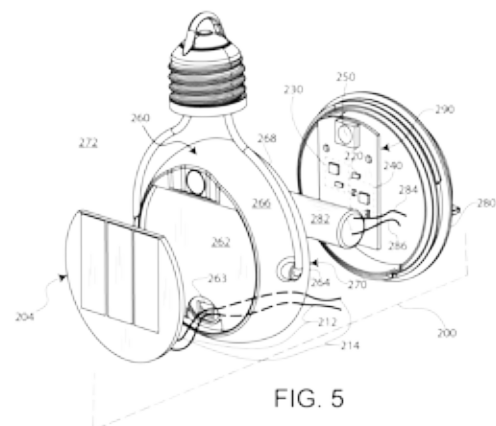

Photo: (c) Nokero Intl. Ltd.



Launched in October 2015, Nokero's patented N233 lamp (above) can produce 700 lumen-hours per watt. The industry standard is 300 lumen-hours per watt. Intellectual property plays a critical role in Nokero's business strategy enabling it to protect its inventions and its brand as well as the interests of investors and distributors.



Photo: (c) Nokero Inti. Ltd.

Equipped with Nokero lamps, children in a village near Victoria Falls in Zimbabwe, have a good source of lighting and can study for up to four hours after dark



Photo: (c) Nokero Inti. Ltd.



Photo: (c) Nokero Inti. Ltd.

Some 1.3 billion people still rely on kerosene to light their homes at night. Kerosene is an expensive, poor-quality and polluting light source that can cause severe health problems. Nokero's lamps offer an affordable eco-friendly alternative.



So far Nokero's lamps have expanded the livelihood options, and improved the safety of some 7 million people in 120 countries.



Photo: (c) Nokero Intl. Ltd.

When it comes to patenting, because we operate in so many different markets, we use WIPO's Patent Cooperation Treaty (PCT). Every start-up has limited funds and the PCT is a great mechanism for delaying patent filing costs, allowing time to test the market and overcome any unforeseen technical problems. Without the PCT, protecting an invention in international markets would be a high-risk strategy with huge upfront costs.

In 2013, we even won the *Patents for Humanity* award from the United States Patent and Trademark Office (USPTO). We hold around 20 patents and have successfully sued a number of infringing companies. Our patent and trademark rights enable us to protect our inventions and our brand as well as the interests of our investors and the efforts of our distributors.

***How long did it take to develop your first solar-powered light bulb and how has the technology advanced since you first developed it?***

From conception in January 23, 2010 to public launch it took just five months. That is about as fast as we could go, given the need for production tooling, branding, website development, and so on. Product development takes longer now because our products are more complex. The first product we launched was about 200 lumen-hours per watt (of solar panel). In October 2015 we launched our latest product, which reaches 700 lumen-hours per watt. The industry-standard is 300 lumen-hours per watt, so we are leading by a huge margin. Our newest product, the N233, is twice as good as anything we have tested but only costs 10 percent more to make. We believe that the small improvements we have made to the N233 make it the most durable solar light yet.

***There are a number of entities tackling energy poverty – what makes Nokero stand out?***

Nokero is unique in the expanding off-grid solar sector. We have the technical capability, but we also have the IP to protect our position. This makes us unique in an industry that is full of copycat products that are eroding trust in solar solutions. Over the long term, Nokero will have a unique design and performance that is defended by a global IP portfolio.

***What is your long-term goal?***

To improve tens if not hundreds of millions of lives.

# Eight steps to secure trade secrets

By **Pamela Passman**, President and CEO, Center for Responsible Enterprise And Trade (CREATe.org), Washington DC, USA, and former Corporate Vice President and Deputy General Counsel, Global Corporate and Regulatory Affairs, Microsoft Corporation.

International cyberattacks with the intent to steal intellectual property (IP) continue to dominate the news, leaving many firms scrambling to shore up their computer networks to thwart such hacks.

However, the greatest threat may be already within a company. In more than 85 percent of the trade secret lawsuits in state and federal courts of the United States, the alleged misappropriator was either an employee or a business partner. That is the startling finding of *A Statistical Analysis of Trade Secret Litigation in Federal Courts* ([www.omm.com/files/upload/AlmelingGonzaga-LawReviewArticle.pdf](http://www.omm.com/files/upload/AlmelingGonzaga-LawReviewArticle.pdf)), which is believed to be the first statistical study on the subject.

How do you secure company trade secrets from both external threats and potential thieves already inside the company?

Increasingly, the courts are saying that firms need to take “reasonable steps” to protect confidential corporate assets, and these efforts include not only securing computer networks but also embedding trade secret protection into business operations and processes.

Determining the extent of “reasonable steps” can be challenging since governments have been vague about the term’s definition. Laws and legislation also continue to evolve. However, research into court cases reveals the key elements of an effective trade secret protection plan.

## PROTECTING CORPORATE CROWN JEWELS

*The Statistical Analysis of Trade Secret Litigation in Federal Courts* found that confidentiality agreements with employees and business partners were the most important factors when courts decided companies had taken reasonable measures to protect trade secrets. However, winning suits reveal that companies can and should take a number of additional steps to build a case for legal redress in the event that their corporate crown jewels are compromised.

The eight categories of a comprehensive protection plan include:

- creating agreements, policies, procedures and records to establish and document protection;
- establishing physical and electronic security and confidentiality measures;
- assessing risks to identify and prioritize trade secret vulnerabilities;
- establishing due diligence and ongoing third-party management procedures;
- instituting an information protection team;
- training and capacity building with employees and third parties;
- monitoring and measuring corporate efforts;
- taking corrective actions and continually improving policies and procedures.





Photo: iStockphoto/LagartoFilm

International cyberattacks continue to attract media attention, but a recent study shows that the greatest threat may lie within companies.

### 1. IMPLEMENT BUSINESS PROCEDURES TO AUGMENT NON-DISCLOSURE AGREEMENTS

As the study confirmed, confidentiality and non-disclosure agreements with employees and business partners constitute a great first line of defense and have won praise from the courts. In addition, the courts have said a company's overall corporate policy is important for maintaining confidentiality as evidence that it protects trade secrets.

Companies should also develop procedures to make sure corporate policies are followed, and that protections and compliance are documented. The implementation of specific procedures to support aspects of company confidentiality policies are often cited favorably in cases. Such procedures range from asking employees to return confidential information when leaving a company to marking documents as confidential, or not letting any single employee or third party have access to a full process, formula or other type of sensitive information.

Policies, procedures and records also need to be followed consistently to qualify as "reasonable steps".

For example, when the PatientPoint health information service brought a legal action to prevent a terminated employee from using competitive, sponsor and other information that he had access to during his employment, the court found that PatientPoint had not asked for a non-disclosure agreement until a year after he started working. In addition, the company did not demand that he return his laptop and confidential information until six months after he left.

### 2. CONTROL PHYSICAL AND ELECTRONIC ACCESS

Most companies know that physical and electronic security is very important for protecting intellectual property, and courts are increasingly requiring it. For example, Japanese courts have found that a company must "implement physical and electronic access restrictions" in order for information to be deemed "kept secret" and thus protected by Japan's unfair competition rules for trade secrets.

Companies should also incorporate confidential information protection into physical and information technology

(IT) security system planning as well as restricting system access, and should regularly assess and improve their systems.

### **3. IDENTIFY, ASSESS AND TAKE STEPS TO MANAGE RISKS**

It is difficult to make a case supporting trade secret theft without first identifying the information deemed to be confidential. As a first step, trade secrets should be documented in an internal registry. Next, an assessment of the risks should be made in the event that they are stolen. Which areas are most at risk of breaches and leaks? Which departments are most vulnerable? Once identified, companies should take additional measures to secure those critical areas.

Companies that have included particular material in a trade secret registry have been determined by courts as making “reasonable efforts” to maintain that confidentiality. In a classic case from 1991, electronics firm Texas Instruments (TI) prevailed in a case against two former researchers who had copied all of its computer directories and then left to join a competitor. In convicting the ex-employees, the court cited TI’s trade secret registry, among a long list of other “reasonable efforts” that TI had taken, as evidence that TI’s technology and software was protectable.

### **4. CREATE SUPPLY CHAIN PROCEDURES AND PLANS**

Third parties, including those in joint ventures, suppliers, distributors and even customers, can have access to a company’s trade secrets for manufacturing, product development or other collaborations. As these partners are a potential source of misappropriation, it is vital to have processes in place to protect confidential assets. Third-party non-disclosure agreements can be considered a reasonable protection effort but agreements are not enough. Companies should also include trade secret protection as part of their due diligence criteria, conduct ongoing reviews of processes in place for keeping information confidential and regularly communicate with third parties about expectations around trade secret protection.

### **5. CONDUCT EMPLOYEE AND VENDOR TRAINING**

Training is essential for employees and third parties so both groups know what is expected of them when

handling such information. Failure to take these simple steps – which can fall outside basic corporate training – has resulted in some companies not gaining the protection of the law. While several companies have won theft cases against former employees based upon their corporate training procedures, the courts found that the MBL (USA) Corporation failed to inform employees “what, if anything, [the company] considered confidential,” which was a key fact that led the court to dismiss MBL’s case against its former employee.

### **6. ASSEMBLE A TRADE SECRET SWAT TEAM**

Problems arise when no one within a company has overall responsibility for protecting trade secrets and other confidential information. Courts have not looked favorably on companies that have not put a person or group in charge of trade secret protection. Best practices also point to establishing a cross-functional team with representation from those who can ensure that trade secret protection policies are being followed.

When a former employee of a bookkeeping company was charged with violating trade secrets by using its client lists, the case was dismissed when it turned out the public also had access to client names. The names had been left on the company’s reception desk, on employee desks, on computers to which another company in the building had access, on computers where the passwords were left on the desk or shouted across the room, and in areas where the public and janitorial staff could see them. No one appeared responsible for protecting this information.

### **7. MAKE CONTINUAL IMPROVEMENTS**

Unfortunately, trade secret protection might only be addressed at key milestones such as a new joint venture. In reality, such protections should be ongoing. Efforts to protect trade secrets should be monitored annually and procedures updated often to maintain consistency and ensure compliance.

Also, as companies grow, procedures and policies change. Trade secret protection plans should also evolve. In trade secret breach cases, the courts have examined corrective actions as criteria to determine whether the company has taken “reasonable steps” to protect its trade secrets. Additional leading practices for corrective actions and improvements include developing a rapid response plan, root-cause analyses of issues, and tracking.



Photo: Stockphoto/wahahaz

## 8. MAKE TRADE SECRET PROTECTION A PRIORITY

Today, cyber threats, the digitization of information, complex supply chains and movement of employees between companies and continents put a company's valuable trade secrets at increased risk.

To protect critical business information, companies need to boost security and, importantly, put systems in place to ensure trade secret protection. This approach helps companies both mitigate risks and also meet the "reasonable steps" requirement in the event that trade secrets are compromised. Not doing so can risk a company's revenues, reputation and competitive edge.

A white paper on the "*Reasonable Steps*" requirement is available at: <https://create.org/resource/reasonable-steps-to-protect-trade-secrets-leading-practices-in-an-evolving-legal-landscape>.

In an increasingly digital economy where employees move between companies and continents, companies need to boost security and put systems in place to protect critical business information and safeguard valuable trade secrets.

# Selling ideas – the future of jobs

By **Sandeep Chatterjee**, Founder & CEO, EVx

*Sandeep Chatterjee was named a Young Global Leader by the World Economic Forum. Earlier, his Ph.D. dissertation at the Massachusetts Institute of Technology (MIT) was selected as one of the top inventions in computing, and is preserved in a time capsule at the Museum of Science in Boston, Massachusetts (USA).*



Photo: EVx

“With the right support, anyone can have a good idea and succeed,” say Sandeep Chatterjee, EVx founder (center).

Technological advances are making it easier and faster to translate ideas into commercial products. For example, new software tools and programming languages allow for the development of software systems in a matter of days instead of months. Physical goods can also be readily fabricated or manufactured. In fact, 3D printers will soon bring manufacturing directly into our homes and offices.

In line with this trend, the true value of a product or service is becoming more about its underlying idea and less about its implementation. In this context, larger companies typically have the operational and marketing capabilities to translate ideas into commercial products and to bring them to market quickly and cost-effectively. What these companies may lack, however, is a steady flow of good ideas to generate value in a sustainable way. Many individuals, on the other hand, including college students, professors and professionals, have great ideas but lack the means or know-how to commercialize them. How can these often brilliant ideas be harnessed? What needs to be done to connect these creative individuals with the companies that have the interest and the means to bring their ideas to market?

That is where I believe the Emerging Ventures Exchange platform (EVx, [www.evxglobal.com](http://www.evxglobal.com)) and its global ideas network have a role to play.

## THE BEGINNINGS OF THE EVX IDEAS NETWORK

Since the early 2000s, I have been running an intellectual property (IP) and commercial litigation company in the United States, and have been working with the largest companies and law firms in the world on IP valuation, commercialization and litigation issues. Also in the early 2000s another of my companies was involved in a United States Agency for International Development (USAID) project to build one of the first secure e-banking platforms for the millions of people around the world who do not have access to banking

“ The EVx platform gives people the chance to earn money from their ideas without bearing the risks associated with starting a company”.

services. The project was successfully piloted in Uganda, and subsequently rolled out in other countries in Africa, Asia and Latin America. I soon realized, however, that the people we were serving – in semi-urban, rural and remote communities – had little or no money to transact with the bank. What they really needed was a reasonable source of income!

Time and again when travelling in emerging market countries, I encountered college students, academics, professionals and others with great ideas for new products and services or ways of improving existing ones. Unfortunately, many of those ideas simply fell by the wayside because the people who hatched them lacked the resources and the relevant connections to commercialize them. Even if they did connect with investors or companies, they found it difficult to communicate and negotiate effectively with them. All too often these potentially valuable ideas ended up at the bottom of a desk drawer.

My experience in monetizing IP convinced me that if these innovative individuals could be connected with companies that would buy and commercialize their ideas, everyone could benefit. This prompted me to develop the EVx platform.

#### **A “GO-TO” PLATFORM FOR WORKABLE IDEAS**

Good ideas are everywhere. They are not exclusive to highly educated researchers in major laboratories. In fact, some of the most commercially successful ideas have come from individuals who simply identified a problem and devised a practical solution to overcome it.

With the right support, anyone can have a good idea and succeed. The EVx platform seeks to do just that. EVx is a global ideas network that offers anyone with a workable idea – regardless of their education or background – a chance to earn income from it.

EVx partners with universities, trade associations and individuals around the world and teaches people how to develop their ideas. Our aim is to empower people, specifically in emerging market countries, to develop their ideas and translate them into financially viable products. We provide practical educational courses online, through our Web portal and mobile app, and in classrooms. EVx also provides directed training and guidance on the technologies and subjects that are of interest to industry, giving EVx members an opportunity to focus their time and resources on these critical areas.

Any idea can be posted onto the EVx platform as long as it works and solves a real-world problem. A prototype



or a patent is not a requirement to use the platform. But steps taken to develop the idea, such as a proof of concept, software source code, hardware circuit design, or a patent application, usually mean that companies will pay more for it.

When an individual joins the EVx platform, they simply post a written description of their idea through our proprietary content delivery system. The idea is then made available to our expanding network or corporate partners, of which there are now over 60.

EVx offers its members a complete solution, starting with practical, real-world training and ending with a direct mechanism to monetize that know-how and their ideas.

### **A GATEWAY TO COMMERCIALIZATION**

By becoming a member of EVx, college students, professors, professionals and others can focus on what they do best – developing good ideas and solutions – without having to spend their limited time and money on identifying investors or companies that are interested in buying and commercializing their ideas.

The platform is a gateway to companies that can commercialize ideas with market potential and put money into the hands of individual inventors and creators. At the same time, it relieves inventors and creators of the need to negotiate complex licensing deals or to pay for the legal expertise to draft and finalize licensing agreements for their ideas.

Our aim is to remove many of the barriers to commercial success. Once ideas are posted, inventors simply sit back and wait to hear from interested companies. If more than one company is interested, the inventor or creator selects the preferred buyer and purchase price.

A successful transaction via the EVx platform can generate far-reaching benefits. Anyone with a good idea has an opportunity to generate income from it. Companies usually pay members a large lump-sum through the platform. These funds often benefit entire families, securing the livelihoods of dozens of people.

### **BENEFITS FOR COMPANIES**

All companies are hungry for good ideas and new commercial opportunities. They are not necessarily looking for major scientific breakthroughs, but for new product ideas or ways to improve existing products or services.

The automobile sunshade, for example, is essentially a piece of cardboard cut into the shape of a windshield that blocks the sun and prevents the inside of the car from heating up and suffering heat damage. It is a practical solution to a real-world problem and now represents a multimillion-dollar industry. Through the EVx platform, such simple and practical ideas, as well as more complex ones, can be purchased outright or licensed by companies.

While companies may not pay millions of dollars for these ideas, they may well pay between USD500 and USD100,000 and sometimes much more. These amounts represent several months or even several years of income for many living in emerging economies.

I see the EVx network as a win-win solution. It offers companies ready access to interesting new product ideas and cutting-edge research, providing a useful and cost-effective complement to in-house research and development (R&D) efforts, where they exist. It also offers individuals with smart ideas an opportunity to generate income.

### **THE FUTURE OF JOBS**

The technological advances we are witnessing today are having an enormous impact on the jobs market. For example, in the software industry, new technologies, tools and programming languages are enabling software systems to be developed in days instead of months such that companies no longer need large software development teams. This is already evident in countries like India where many outsourced development companies are hiring fewer software engineers.

As the number of available software engineering jobs dwindles, more and more people are earning their livelihood and securing an income from selling their ideas to companies that can commercialize them. And as implementation technologies and tools advance, it is likely that the amount paid for these ideas will rise.

Individuals who successfully commercialize their ideas through EVx are often recruited by the platform's corporate partners and other companies around the world. All companies are looking for innovative, practical and creative thinkers who can add value. As successful EVx members have proven their worth, employers in India, the United States and elsewhere are eager to hire them. In fact, EVx itself has hired a number of them.



Photo: xxxxxxxxx

EVx connects individuals with ideas to an expanding network of corporate partners. It creates opportunities for people to generate income from their ideas, often to the benefit of entire families.

### TRADITIONAL ENTREPRENEURSHIP IS TOUGH

Starting and growing a company is hard! Nearly 90 percent of all start-ups fail. Despite its many challenges, there is today a big push in many emerging economies to promote entrepreneurship. Many who seek (or are pushed) to become entrepreneurs are ill equipped to do so and often put their livelihood and that of their families at risk to establish a business, only to see it fail.

EVx offers a low-risk route to entrepreneurship. It gives people the chance to earn money from their ideas without bearing the risks associated with starting a company. In some cases, having received payment for their idea, EVx members can also license the product back and set up their own company to commercialize it in their own country. This “early taste of success” is what drives future entrepreneurs and enables them to succeed.

### THE GLOBAL SCOPE OF EVX

EVx is a global platform that consists of an expanding network of nearly 320,000 individuals (including over 600 colleges and universities). Our aim is to have over one million members by the end of 2016. Our main focus is

India, China and Latin America but there is also strong interest in other Asian countries and Africa.

### NEW INCOME OPPORTUNITIES

Jobs, poverty alleviation and financial empowerment are critical areas for all governments and are widely discussed at multiple global fora. The orthodox view is that better education and increased foreign investment will lead to more jobs. This may work, but is likely to take decades. What about the people who need money so they can live and buy food for their families today? People do not necessarily need jobs, but they do need money so that they can provide for themselves and their families.

EVx offers new opportunities for people from all walks of life to generate income, for companies to prosper and for consumers to enjoy new and improved products and services.

# Five tips for managing your patent assets

By **Jason M. Schwent**, Thompson  
Coburn LLP, Washington, USA

Patent protection is one of the most important ways companies can safeguard their assets. Patents provide an unequalled head start in the marketplace. With patent protection, your business can work out all the growing pains associated with your new technology, perfecting it and its distribution, before your competitors start. But even more importantly, patents allow you to prevent latecomers from getting a foothold. Patent protection prevents your competitors from making, using, selling, offering to sell, or importing your technology in the country or countries in which patent rights are held. That sort of exclusivity is immeasurably valuable, especially where key technology is involved.

But patents are not cheap. Most businesses cannot afford to patent (or attempt to patent) all their technological advances. So how can businesses most effectively manage their technology and patent strategy so that they receive the protection they need when they need it? Here are five tips for managing your patent assets.

## 1. Prioritize patenting

It sounds simple, but if you want your business to maximize patent assets, you need to make patenting your technology a priority. This means more than simply patenting those technological advances your company considers to be valuable. This allows far too many assets to slip through unprotected and risks unauthorized disclosures along the way – invalidating some potential patents.

Maximizing patent assets requires a company-wide commitment to protecting intellectual assets. This means educating employees on what sort of advancements can be patented. Unfortunately, many engineers, developers and research and development personnel undervalue their technological advances, but identifying all possible inventions means more exploitable technology for the company.

Maximizing patent assets also means educating your management on the costs associated with patenting technology. Patent acquisition is not cheap, although there are systems such as the Patent Cooperation Treaty (PCT) which offer a cost-effective means of protecting patents internationally (see box). Patenting costs need to be seen as an investment in the company and not expenses to be cut. And, perhaps most importantly, prioritizing patents means enforcing the patents you do obtain against infringers. Patent infringement actions are very expensive. But without enforcement (or the credible threat of enforcement), patents are not worth the paper they are printed on.

## 2. Identify early

One of the most important tips for managing your patent and potential patent assets is to have a process in place to identify key technological advances early in the development process.

Knowing what technology is being developed and carefully evaluating it with an eye toward the marketplace will allow the company to muster the assets necessary to protect key advances. This evaluation should not be limited to research and development personnel alone. Ideally, for maximum returns, key marketing, sales and management personnel, should all be involved in this evaluation together with research and development personnel and a qualified patent attorney. While this evaluation is critical, it also needs to be quick. Research and development often moves at a frenetic pace. Evaluation should not slow this process, but should be integrated in a way that allows for seamless identification and evaluation.

And perhaps most importantly, early identification of key technology can help prevent unauthorized disclosures. When technology is exposed to the public (whether through use, publication, sale, or offers for sale), the



## About the Patent Cooperation Treaty (PCT)

The Patent Cooperation Treaty (PCT) offers users of the patent system a streamlined and cost-effective means of protecting their inventions internationally.

The PCT eliminates the need to file separate national or regional patent applications in each jurisdiction for which patent protection is required. The granting of patent rights, however, remains under the control of the national or regional patent offices concerned.

By filing a single “international” patent application within 12-months of filing the first patent application with its national patent office, an applicant can set in motion the process of obtaining patent protection simultaneously in 148 countries.

The PCT also helps national patent Offices with their patent granting decisions; and facilitates public access to a wealth of technical information relating to inventions through the Patentscope database. Further information is available at: [www.wipo.int/pct/en/faqs/faqs.html](http://www.wipo.int/pct/en/faqs/faqs.html).

Maximizing a company's patent assets requires a company-wide commitment to protecting intellectual assets..



ability to patent it is lost. There is little more frustrating than spending a fortune developing an important, groundbreaking technology, only to find that it is not patentable because a marketing leaflet was sent to key customers during development or because of a trade show demonstration of the technology. Both of these acts would in effect destroy the novelty of the technology, which is a core requirement for obtaining a patent. Identifying key technology at an early stage can help the company make sure that early, unauthorized disclosures are avoided – preserving its ability to acquire rights in that technology for protection at a later date.

### **3. Exploit hits to the hilt**

Research and development does not always produce valuable technology, which is why when technological advances are made it is important for the business to extract every possible bit of monetary return from it. This requires identifying and exploiting all possible iterations of the technology at issue. This process should ideally include the same cross-disciplinary personnel as above, with a qualified patent attorney, to ensure that possible modifications are understood and appropriately covered by additional patent applications. Multiple patents and patent applications should be filed for every way that a particular technology can be practiced, to ensure that competitors are unable to modify your technology easily and that your exclusive use of that technology lasts as long as possible.

### **4. Incentivize development**

Obviously, one of the keys to a successful patent strategy is a steady succession of new and valuable technological advances. In addition to excellent research and development personnel and evaluators capable of identifying technologies that can be exploited, it also requires an effective incentive program to reward those involved in the process. While the business must ensure that any and all developments made by its personnel are exclusively owned by the business, this does not mean that bright, innovative employees should not receive adequate reward for their achievements. The business should have in place an incentive program that encourages all employees (not just those tasked with developing new technology) to innovate on behalf of the company. And where that innovation benefits the business, those involved should share in the profit.

### **5. Keep an eye on your competitors**

Finally, any good patent asset management strategy must include some idea of what competitors are doing in the marketplace. This monitoring serves two main purposes: one defensive and one offensive. First, by monitoring what the competition is doing, a business can ensure it stays at the forefront of technology and is in a position to develop responsive technology when competitors achieve technological breakthroughs. Effective monitoring of the competitive landscape can be achieved by, for example, encouraging salespeople to report on the new technology they encounter in the field. Marketing personnel should also be encouraged to monitor what the competition is saying about its new technology and development. Key personnel should also attend national conferences to identify technological trends and cutting-edge developments. These steps help ensure the business is never far from the technological forefront. Companies can also use publicly available patent databases such as Patentscope to monitor the patenting activity of competitors (see box) or take a look at patent landscape reports which offer a snapshot of the patenting situation of a specific technology in a given country or countries.

The second reason for monitoring is to make sure that instances of infringement are promptly identified and stopped. As noted earlier, patent rights are worthless unless enforced. When infringing technology is found in the marketplace, it should immediately be brought to the attention of management so that appropriate steps can be taken to put an end to it. Again, sales and marketing personnel should be encouraged to report potentially infringing activity and customers should also be encouraged and incentivized to report on such activity. By actively investigating possible infringement and taking steps to halt it, the business maximizes the value of its patent rights and gets maximum return on its research and development investment.



## About Patentscope

WIPO's Patentscope is a publicly available (free-of-charge) global patent search system. It provides access to information about new technologies which are often disclosed for the first time in patent applications.

The Patentscope database currently contains over 50 million patent applications comprising international applications filed under the Patent Cooperation Treaty as well as 41 national and regional patent collections.

Patentscope offers users working in multiple languages a wide range of user-friendly search tools, making it easy to access the valuable technological information contained in the database.

Further information is available at:  
[www.wipo.int/patentscope](http://www.wipo.int/patentscope)

Identifying key technological advances early on in the development process enables businesses to effectively protect them and to extract maximum value from them.

# Court confirms legal status of *Happy Birthday to You!*

By C. Dennis Loomis, Partner,  
BakerHostetler, Los Angeles, USA

*Happy Birthday to You* has been called the best known song in the world. Certainly, one would be hard pressed to find anyone who has not sung and heard it dozens if not hundreds of times.

But you may not have known that for decades Warner/Chappell Music and its affiliate Summy-Birchard, Inc. demanded and received millions of dollars in copyright royalties from thousands of companies and individuals for the right to include renditions of *Happy Birthday* in movies, TV shows, music videos and the like, basing their claim on a copyright registration dating back to 1935.

## CLASS ACTION CHALLENGES WARNER/CHAPPELL'S COPYRIGHT CLAIM

In 2013, in separately filed lawsuits, Warner/Chappell's copyright was challenged by several individuals and small production companies. One of these plaintiffs, Good Morning to You Productions Corp., was working on a documentary about *Happy Birthday to You* and was moved to action when Warner/Chappell demanded a USD1,500 license fee to reproduce the song in its film. These cases were consolidated into a single coordinated class-action lawsuit (*Good Morning to You Productions Corp., et al. v. Warner/Chappell Music, Inc., et al.*, Case No. CV 13-04460-GHK (MRWx), US District Court, Central District of California), seeking a declaratory judgment that Warner had no valid copyright covering *Happy Birthday* and demanding restitution of the license fees paid by all members of the class during the three years preceding the lawsuit (the applicable statute of limitation for such recoveries).

## THE QUEST TO TRACE COPYRIGHT OWNERSHIP

The tortuous legal history of *Happy Birthday to You* begins in 1893, when Clayton Summy filed for copyright registration in a songbook entitled *Song Stories for the Kindergarten*, assigned to him by author/composer

sisters Mildred and Patty Hill. One of the songs, *Good Morning to You*, included the now-familiar *Happy Birthday* melody but was set to the words "Good morning to you, Good morning to you, Good morning dear children, Good morning to all." Mildred was the composer, and Patty wrote the *Good Morning* lyrics. In 1921, following Mildred's death, third sister Jessica Hill filed for renewal of this copyright. Copyright protection for the *Happy Birthday* melody thus expired in 1949, at the end of the 28 year renewal term under the copyright law then prevailing.

## COPYRIGHT CLAIM COVERS LYRICS ONLY

Warner/Chappell concedes that the *Happy Birthday* melody is in the public domain, and bases its copyright claim exclusively on the *Happy Birthday* lyrics. Under US copyright law, rights in the words and the music comprising a song may be separately owned, separately copyrighted and separately enforced. Generally, the author of song lyrics owns the copyright in that work upon creation. (The exception is a work made for hire, where the employer owns the copyright in works created by its employees). Under US copyright law when these events occurred, an author obtained common law copyright in a work upon its creation. Once the work was registered with the US Copyright Office, the common law copyright was superseded by federal copyright law. So long as the author had not affirmatively abandoned its common law copyright or authorized a public distribution of the work, the common law copyright could subsist indefinitely.

## THE CRUX OF THE CASE

The operative question in this case was whether the author of the *Happy Birthday* lyrics had effectively assigned her common law copyright to Warner/Chappell's predecessor-in-interest. This launched the parties on an exhaustive search through newspaper

articles, magazines, copyright office records and court files dating back 100 years and more, to discover who wrote the lyrics to *Happy Birthday to You* and what that person had done with the copyright in that composition.

### **ESTABLISHING AUTHORSHIP IS A CHALLENGE**

Neither party was able to establish with any certainty who had authored the *Happy Birthday* lyrics. In 1901 and again in 1909, publications mentioned the song *Happy Birthday* being sung by children in school gatherings, but did not include all the *Happy Birthday* verses nor say who wrote them. The first publication of the full lyrics occurred in a book for elementary teachers published and copyrighted in 1911. The book noted that *Happy Birthday* was sung to the same tune as the *Good Morning* song first published in *Song Stories*, but did not identify anyone as author of the *Happy Birthday* words. Over the next two decades other song books were published and copyrighted that included *Happy Birthday* with full lyrics but with no attribution to an author of those words.

In the early 1930's, *Happy Birthday* was sung in several motion pictures, and in 1933 it was performed in the play *As Thousands Cheer*. In 1934, Jessica Hill sued the producers of *As Thousands Cheer* for copyright infringement, but not for infringement of the *Happy Birthday* lyrics. Rather, her claim was limited to alleged infringement of the copyrighted *Good Morning* melody that was performed with the *Happy Birthday* words. Warner/Chappell's claim that Patty Hill authored the *Happy Birthday* lyrics was based on her deposition testimony in that case, in which she said that she wrote the words to *Happy Birthday* around the same time as she wrote the words to *Good Morning*. While there was evidence suggesting that someone else may have composed those lyrics, the Court's analysis proceeded on the assumption that Patty was the author.

In 1935, the Clayton F. Summy Company (successor to Clayton Summy's earlier entity) registered copyrights in two works entitled *Happy Birthday to You*. Warner/Chappell predicates its claim of copyright in the *Happy Birthday* lyrics on one of these, registration number E51990. Its theory is that Patty Hill authored the *Happy Birthday* lyrics around 1900, the Hill sisters assigned their common law copyright in those words to Summy Co. in 1935, and then the E51990 filing secured federal copyright registration over the words for Summy Co.

The plaintiffs challenge every significant part of this history. They dispute that Patty Hill wrote the words. They claim that even if she was the author, she either abandoned her common law rights or lost them due to public dissemination of the lyrics. And finally, they assert that any common law copyright that Patty Hill may have owned in the *Happy Birthday* lyrics was never effectively transferred to Summy Co.

With the battle lines drawn, the competing sides each filed cross motions for summary judgment. Such a motion asks the court to rule that there is no genuine dispute about any fact that is material to deciding the controversy, and that based on the undisputed facts, the moving party is entitled to judgment in its favor as a matter of law.



Photo: iStockphoto/Simoningate

### WARNER/CHAPPELL'S ARGUMENT

Warner/Chappell's argument primarily focused on the statutory presumption of validity that attaches to a copyright registration. That statutory presumption (based on provisions in the 1909 and 1976 Copyright Acts), expanded by case law, dictates that the copyright certificate creates a rebuttable evidentiary presumption that the registrant has met all requirements for copyright validity. The E51990 registration includes a deposit copy of *Happy Birthday* including both the music and the words. Warner/Chappell contends therefore that the presumption of validity creates *prima facie* evidence that it owns a valid copyright in those words, which at least precludes summary judgment in favor of plaintiffs.

Warner/Chappell also relies on a 1943 settlement agreement resolving a lawsuit between the Hill sisters and Summy Co. That suit concerned allegations that Summy had exceeded its rights under copyright transfers made by the Hill sisters to Summy in the mid-1930's. Those transfers covered various piano arrangements of *Happy Birthday*. In an agreement settling that lawsuit, the sisters assigned to Summy Co. any copyrights that they might own. Warner/Chappell contends that the claims in that case reflect that the 1930's transfers covered the lyrics, and further, that even if the copyright in the *Happy Birthday* lyrics had not been transferred to Summy Co. previously, this agreement retroactively accomplished that result.

In a class-action suit against the global music publisher, Warner/Chappell, a US District Court recently ruled that Warner/Chappell has not enforceable copyright in *Happy Birthday*, one of the world's most famous songs.

### WHAT THE PLAINTIFFS CLAIM

The plaintiffs contradict this argument by pointing out that registration E51990 states that it is an “Application for Copyright for Republished Musical Composition with New Copyright Matter,” listing the new matter as “arrangement as easy piano solo, with text.” It names the author of the new matter as Preston Ware Oren. The plaintiffs argue that E51990 thus only claims copyright in the piano arrangement of the *Happy Birthday* tune written by Mr. Oren. As no one claims that Oren wrote the words to *Happy Birthday*, the copyright certificate does not create any presumption that Summy Co. secured copyright in the words by that registration. The plaintiffs dismiss the claim that the 1943 Hill/Summy settlement agreement infused copyright protection on the lyrics into the E51990 registration from 1935, because the 1930’s transfers showed no intent to cover lyrics, and the “catch-all” 1943 assignment could not retroactively impute rights into the E51900 registration that were not there in 1935.

### WHAT THE COURT SAYS

The parties first appeared before Judge King to argue their positions on March 23, 2015. The Court subsequently ordered the parties to file additional legal briefs, and held another hearing on July 29, 2015. Finally, on September 22, 2015, Judge King issued his decision in an exhaustive 43 page memorandum. He ruled that the record did not support summary adjudication for the plaintiffs based on the theories that common law copyright in the lyrics had been abandoned or forfeited by publication. Conversely, he concluded that the E51990 registration on its face did not encompass copyright in the *Happy Birthday* lyrics, and so Warner/Chappell was not entitled to summary judgment based on the presumption of validity.

On the question whether Warner/Chappell owned copyright in the *Happy Birthday* lyrics based on the E51990 registration, Judge King decided that there was no credible or sufficient evidence in the record to find that that the Hill sisters had ever transferred any common law copyright in those lyrics to Summy Co. Therefore, as a matter of law, that registration could not have vested any copyright in the lyrics in Summy Co., meaning that Warner/ Chappell has no enforceable copyright in *Happy Birthday*.

Warner/Chappell filed a motion asking the Court to reconsider its decision, asserting that Judge King had failed to afford the E51990 registration the proper presumption of validity, and had incorrectly analyzed the Summy/Hill transfer agreements. Had that motion failed, the case would have proceeded to trial on damages for the plaintiff class. Most likely, a very interesting appeal would have followed.

But in December, the parties reported reaching a global agreement to settle the matter. On February 8, 2016, they filed their proposed settlement agreement as part of a motion for court approval as required for class action cases. The agreement would see Warner/Chappell refund up to USD14 million in license fees paid by class members for use of *Happy Birthday* broken into two classes. “Period one” claimants would receive up to 100 percent of license fees paid after June 13, 2009, up to an aggregate of USD6.25 million. The balance of the USD14 million fund would be paid to “Period Two” claimants, who would receive up to 15 percent of license fees paid from September 4, 1949 to June 13, 2009. A hearing on court approval of the settlement is scheduled for March 14, 2016.



34, chemin des Colombettes  
P.O. Box 18  
CH-1211 Geneva 20  
Switzerland

Tel: +41 22 338 91 11  
Fax: +41 22 733 54 28

For contact details of WIPO's External Offices  
visit: [www.wipo.int/about-wipo/en/offices/](http://www.wipo.int/about-wipo/en/offices/)

**WIPO Magazine** is published bimonthly and distributed free of charge by the World Intellectual Property Organization (WIPO), Geneva, Switzerland. It is intended to help broaden public understanding of intellectual property and of WIPO's work, and is not an official document of WIPO. Views expressed in articles and letters do not necessarily reflect those of WIPO.

For comments or questions, contact The Editor at [WipoMagazine@wipo.int](mailto:WipoMagazine@wipo.int). To order a print version of the WIPO Magazine, contact [publications.mail@wipo.int](mailto:publications.mail@wipo.int).

Copyright ©2016 World Intellectual Property Organization

All rights reserved. Articles contained herein may be reproduced for educational purposes. No part may, however, be reproduced for commercial purposes without the express written consent of the WIPO Communications Division at the above address.